

Capt Dahn

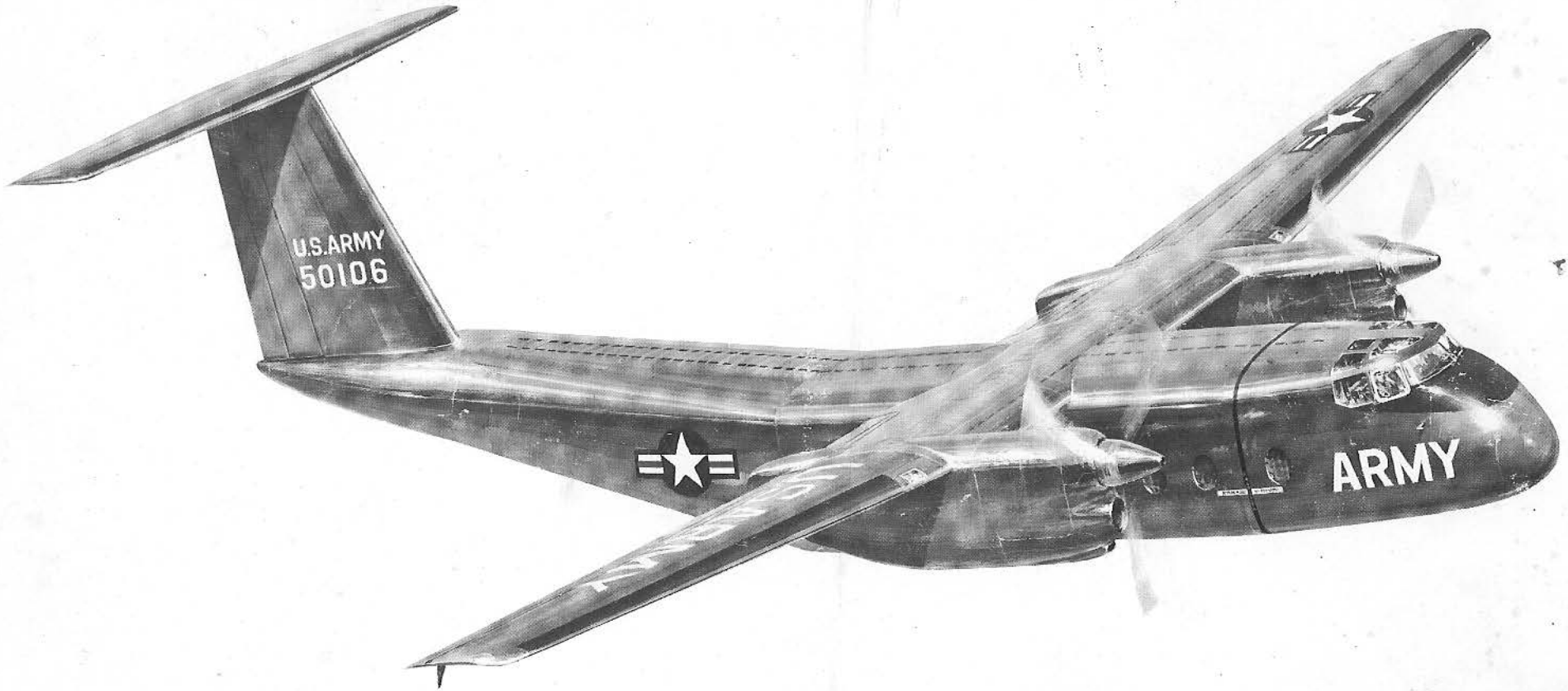

**Caribou II**  
STOL TRANSPORT AIRCRAFT

# TABLE OF CONTENTS

SUMMARY	1
LEADING PARTICULARS	3
OPERATING CHARACTERISTICS	5
DESIGN CHARACTERISTICS	23
PERFORMANCE CHARACTERISTICS	27

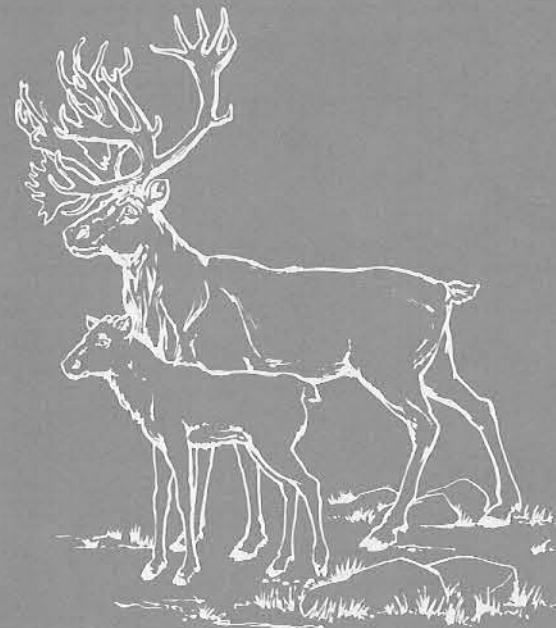

MAINTAINING THE BREED

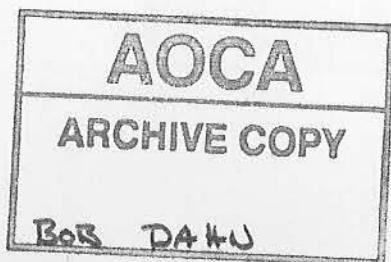

# CARIBOU II DEVELOPMENT MILESTONES

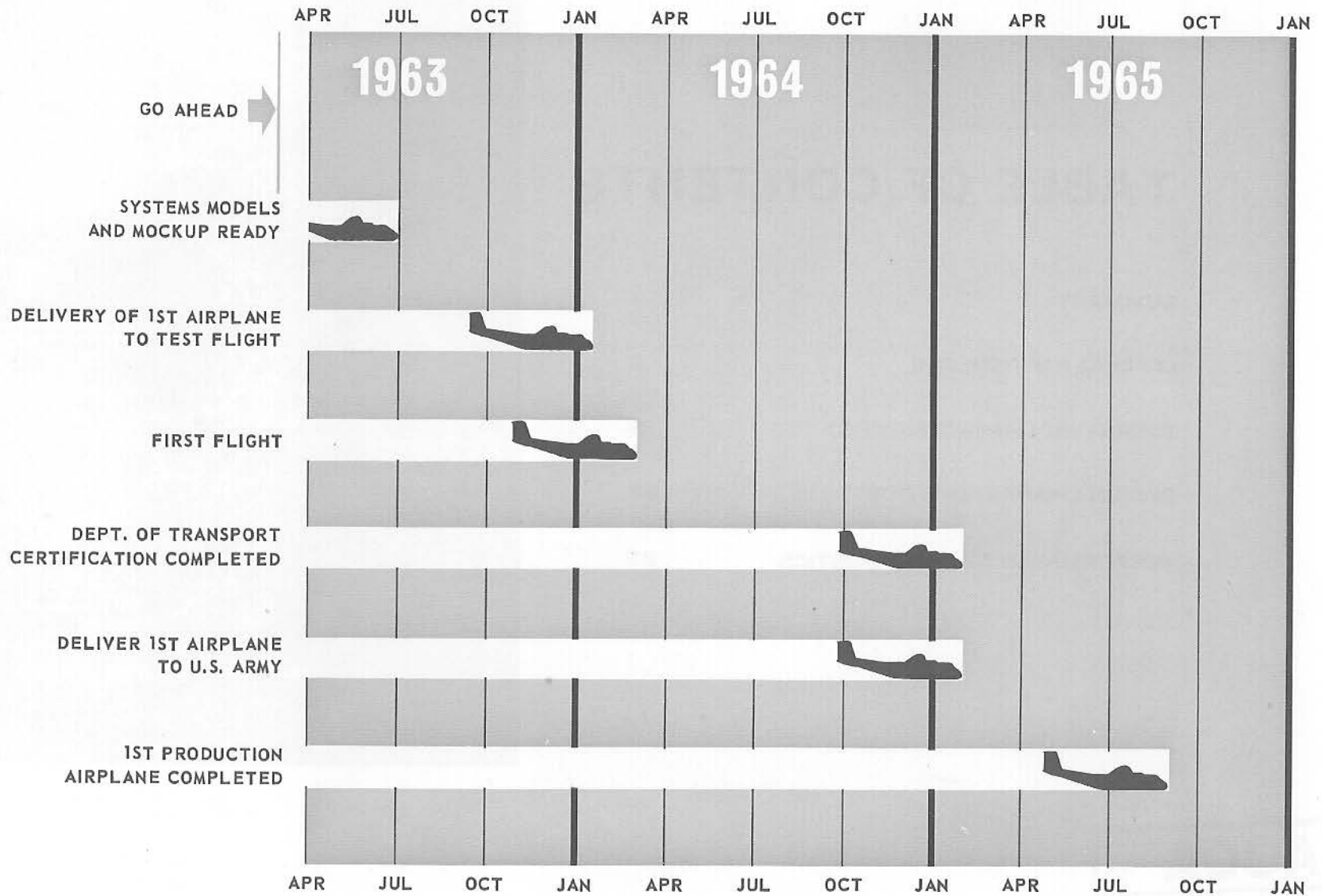

ARCHIVE COPY



## FOREWORD

The de Havilland CV-7A Caribou II is a 5-ton STOL Utility Transport airplane being developed under the joint United States/Canadian Production Sharing Agreement.

The design of the Caribou II reflects the benefits of the accumulated knowledge and service operational experience permitted by the uninterrupted development of the de Havilland family of STOL Utility Transport airplanes from the U-6A Beaver through the U-1A Otter and CV-2B Caribou I. All of these aircraft are in current production and all are in service with the U.S. Army. All have been in operation from the arctic to the tropics.

The 22.5 million dollar budget for the program is being shared equally by the Canadian Government (Department of Defence Production), the United States Government (Department of the Army) and de Havilland Aircraft of Canada Limited. The powerplant will be the highly efficient General Electric T-64 engine

fitted with the Hamilton-Standard 63E60 propeller. These items are to be supplied by the United States Army and will be purchased in the United States. A considerable amount of contractor-furnished equipment for this program will also be purchased in the United States.

The program is an excellent example of United States/Canadian industrial cooperation in defence development for the United States Armed Forces.



# SUMMARY

## INTRODUCTION

The turboprop-powered de Havilland CV-7A Caribou II is a modern all-purpose STOL Utility Transport aircraft which will provide military forces with the benefits of the latest techniques in aerodynamics and powerplant design. Since the design of the Caribou I, turboprop engines of a suitable size have been developed, offering a high power combined with low weight, moderate fuel consumption and good operational flexibility. The availability of these engines has enabled de Havilland to design the Caribou II.

### BACKGROUND EXPERIENCE

The design of the Caribou II is directly based upon the experience gained in the design and operation of the piston-engined Caribou I, which:

- Is now in full production
- Is in intensive use with the U.S. Army, The Royal Canadian Air Force, The Ghanaian Air Force, The Swedish Air Force, The Indian Air Force and Air Asia
- Has accumulated over 40,000 flying hours experience (over 15% of this in an actual combat area)
- Has had world-wide service tests, demonstrations and military operation
- Has shown the practicability of carrying military loads in and out of a great variety of small fields.

### CARIBOU I AND CARIBOU II OPERATIONAL FEATURES COMPARISON

- LARGER PAYLOADS, including modern military missiles and vehicles.
- HIGHER SPEEDS.
- HIGHER RATES OF CLIMB.
- SHORTER TURN-AROUND TIMES, using the latest cargo-handling innovations.
- SAME EXCELLENT STOL AND ROUGH-FIELD CHARACTERISTICS.
- SAME OUTSTANDING VERSATILITY AND ADAPTABILITY.

## STATUS

Development of Caribou II is already well advanced under contracts from the Canadian and United States Governments. Preliminary flight testing of the turboprop engines in a modified Caribou I airframe has already been completed and flight testing of the Caribou II will commence early 1964, with production deliveries in 1965.

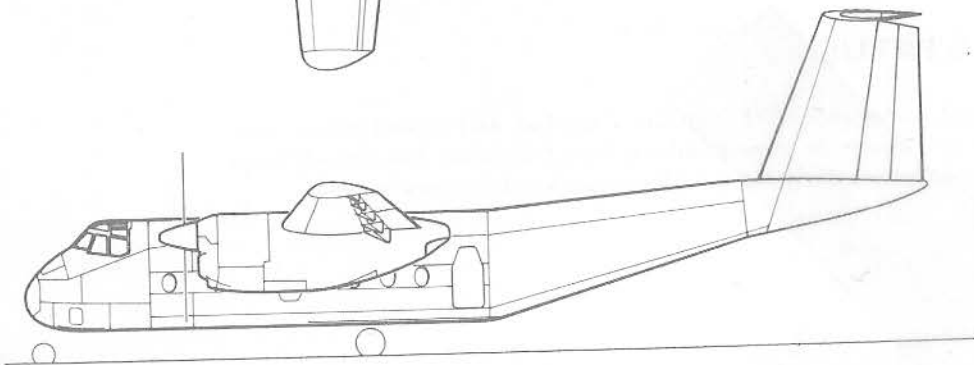
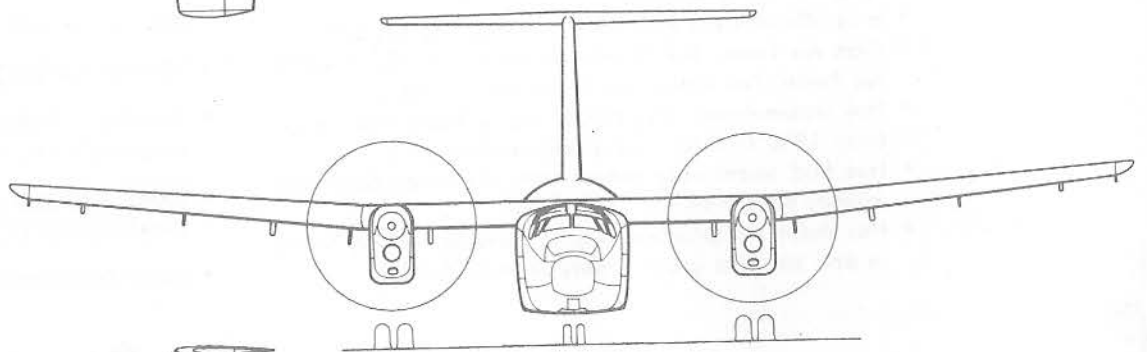
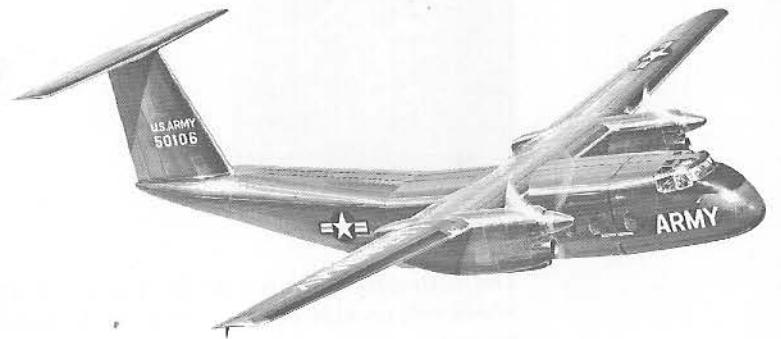
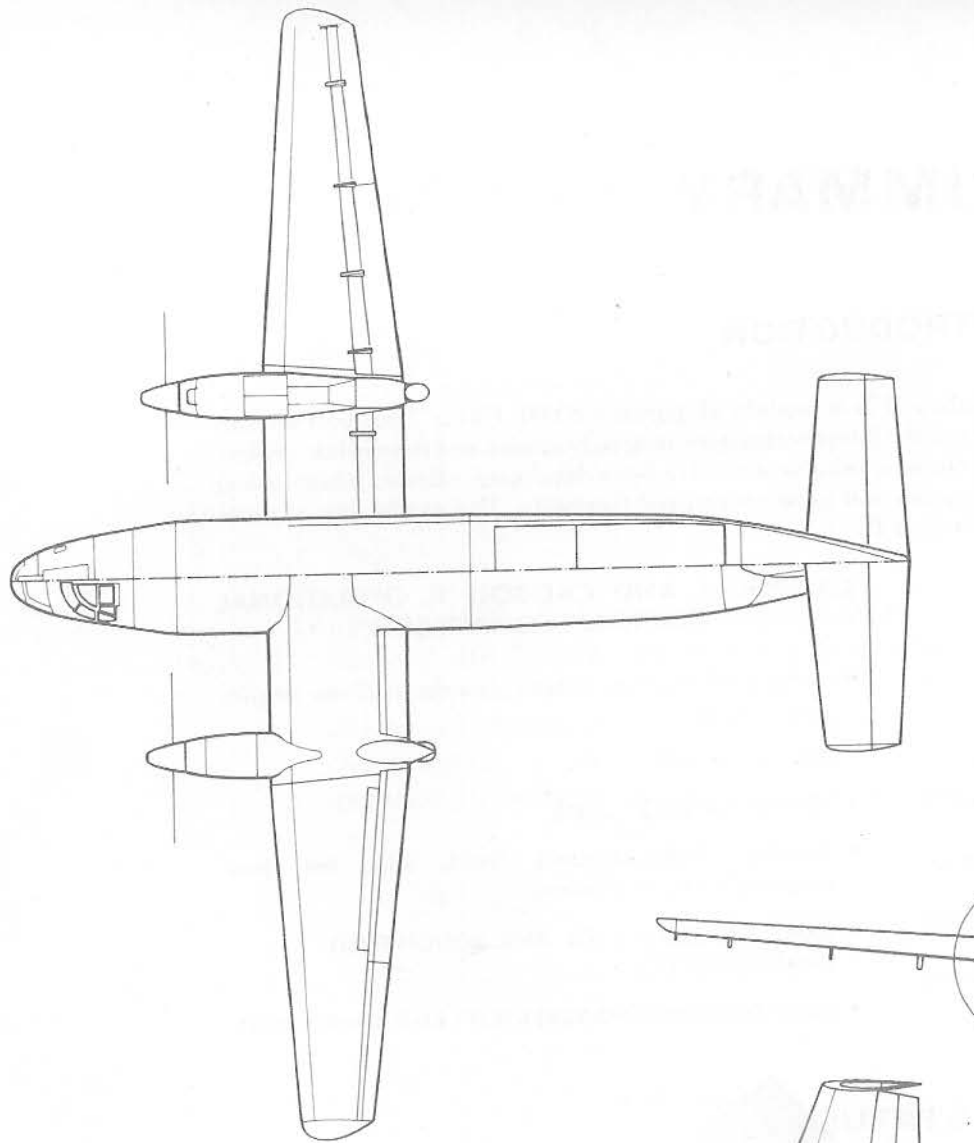



## LEADING PARTICULARS

### GENERAL

Wing span	96.0 ft.	29.3 m.
Wing area	936 sq. ft.	87.0 sq. m.
Wing aspect ratio	9.85	
Length overall	77.3 ft.	23.6 m.
Height over fin	28.7 ft.	8.8 m.
Track of main wheels	30.5 ft.	9.3 m.

### CABIN DIMENSIONS

Length (fwd edge of ramp)	377 in.	958 cm.
Width (maximum)	105 in.	267 cm.
Width (at floor)	93.6 in.	238 cm.
Floor Area	242 sq. ft.	22.5 sq. m.
Height (on centre line)		
aft of rear spar	82 in.	208.3 cm.
fwd of rear spar	78 in.	198 cm.
Volume (rectangular)	1,580 cu. ft.	44.75 cu. m.

### DOOR DIMENSIONS

Rear loading door - width	92 in.	233.7 cm.
Side doors - width	33 in.	83.8 cm.
- height	66 in.	167.6 cm.

### WEIGHTS

Long-range transport take-off	38,000 lb.	17,237 kg.
Short-field (STOL) take-off	34,000 lb.	15,422 kg.
Long-range transport landing	36,500 lb.	16,556 kg.
Unprepared field (STOL) landing	34,000 lb.	15,422 kg.
Zero fuel	34,000 lb.	15,422 kg.
Operational empty weight	22,550 lb.	10,229 kg.
Maximum payload	11,450 lb.	5,194 kg.
Maximum Fuel (Internal tanks)	11,000 lb.	4,990 kg.

### ENGINES

Two General Electric Company T-64 turboprop engines, each rated at 2850 equivalent shaft horsepower for take-off

### PROPELLERS

Two Hamilton Standard 63E60, three blades, 14.5 ft. dia., with integral oil system and reverse pitch

### PROPELLER CLEARANCES

Ground (static at 38,000 lb)	40 in.	101.6 cm.
Fuselage	40 in.	101.6 cm.



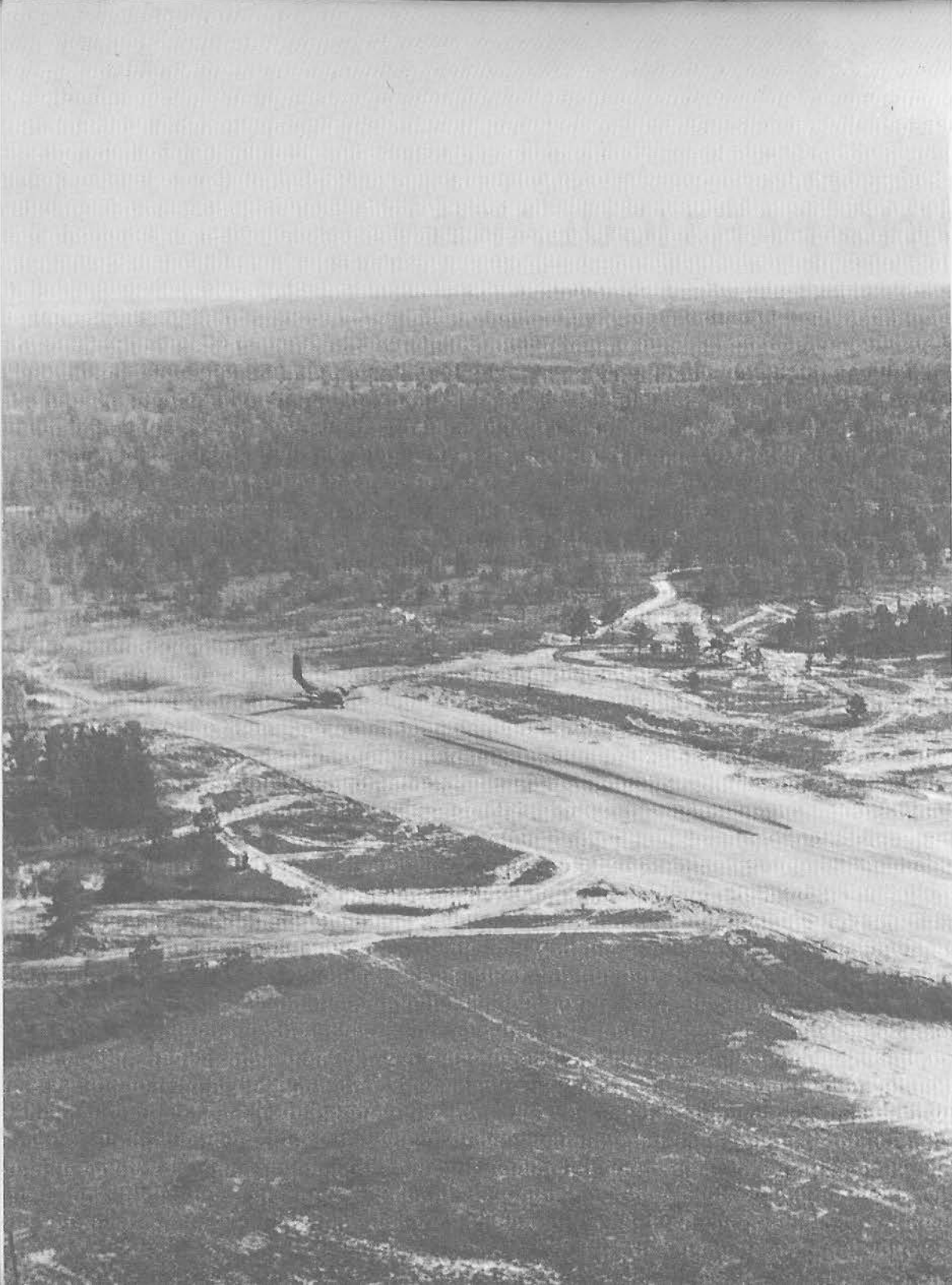

## SHORT AIRSTRIP PERFORMANCE

The short take-off and landing characteristics of the Caribou II enable the aircraft to be flown in and out of hastily prepared landing strips or selected unprepared fields. Its steep angles of descent and climb make it an ideal aircraft for operation from restricted areas. At a weight of 34,000 lbs at sea level, with zero wind conditions, the Caribou II requires only 1,000 feet to clear a 50 ft. obstacle when landing or taking off. With a wind of 8 knots this distance is reduced to 820 feet (landing) and 800 feet (takeoff).

The excellent control and stability at very low airspeeds ensures safe approaches under the most adverse conditions, and guarantees the Caribou II airplane's outstanding short airstrip characteristics. The landing gear has been designed to meet the requirements of rough unprepared field operations. It has a high energy capacity with generous flotation for soft fields. Good ground manoeuvrability in restricted areas is assured by the steerable nose-wheel, power-operated hydraulic brakes and reversing propellers.

U.S. Army tests shown opposite, with the Caribou I have shown excellent reliability under extreme operating conditions.



# OPERATING CHARACTERISTICS

## INDEPENDENCE OF ESTABLISHED AIRFIELDS

The varied demands placed on the military forces emphasize the requirement for a transport aircraft able to operate successfully in any type of terrain and under all weather conditions. For example, direct air supply is the keystone of quick effective military operations, and more and more dependence is being placed upon it. However, this concept will fail unless the final steps beyond airbases capable of handling heavy transports can be taken. Flexibility of operation, which is so important to modern military methods, is greatly enhanced if the supporting air force can operate without reliance on established airbases. Successful search and rescue missions also depend on an ability to operate anywhere and under any conditions.

The operating characteristics of the Caribou II enable it to fulfill these requirements. It has the ability to operate from short airstrips, selected unprepared

fields, anywhere a clearing about 1,500 ft. long can be found. Outstanding low-speed control and excellent low altitude flying qualities allow a safe approach to even the most difficult landing areas.

A rugged high-energy landing gear will tolerate ground contact at high rates of descent. Large low-pressure tires permit operations on unprepared turf, soft desert sand or even on muddy fields which will stop small utility aircraft.

The turboprop engines are fitted with reversing propellers which, with nosewheel steering and power-operated hydraulic brakes, ensure absolute control and manoeuvrability of the aircraft when taxiing in restricted or difficult areas.

The cold weather starting characteristics of turbine engines are well known; they provide immediate aircraft availability under the most extreme conditions.

# TAKEOFF

MAXIMUM PERFORMANCE TECHNIQUE LEVEL SURFACE, SEA LEVEL WEIGHT 34000LB

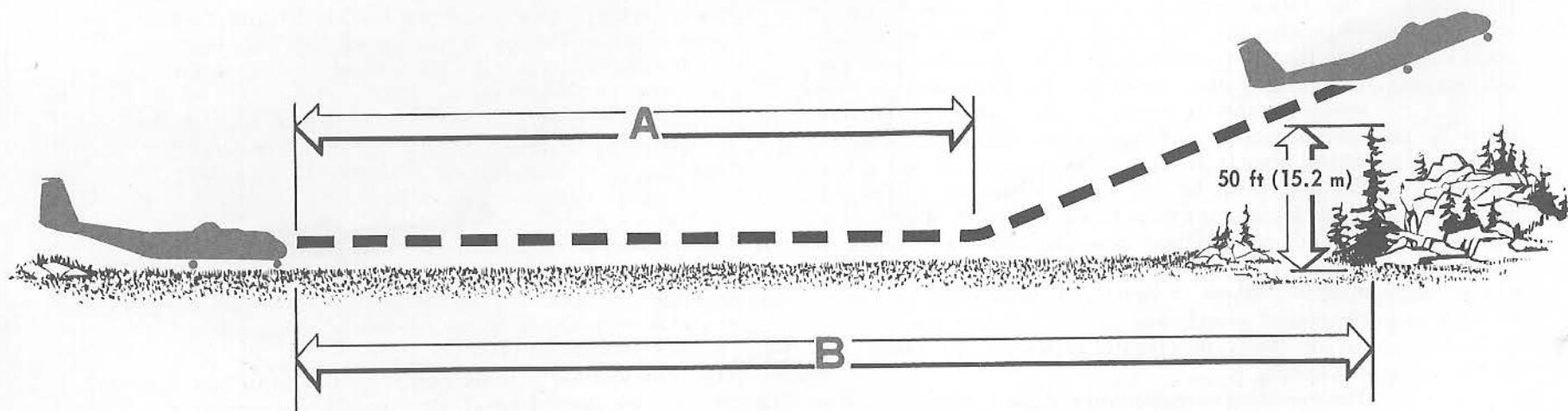

CONDITIONS	A GROUND RUN	B TOTAL TO OBSTACLE	CLIMB GRADIENT
ISA,ZERO WIND	625 ft (190.5 m)	1000 ft (304.8 m)	24.0%
ISA,8 KNOT WIND	480 ft (146.3 m)	800 ft (243.8 m)	27.4%

# LANDING

MAXIMUM PERFORMANCE TECHNIQUE LEVEL SURFACE, SEA LEVEL WEIGHT 34000LB

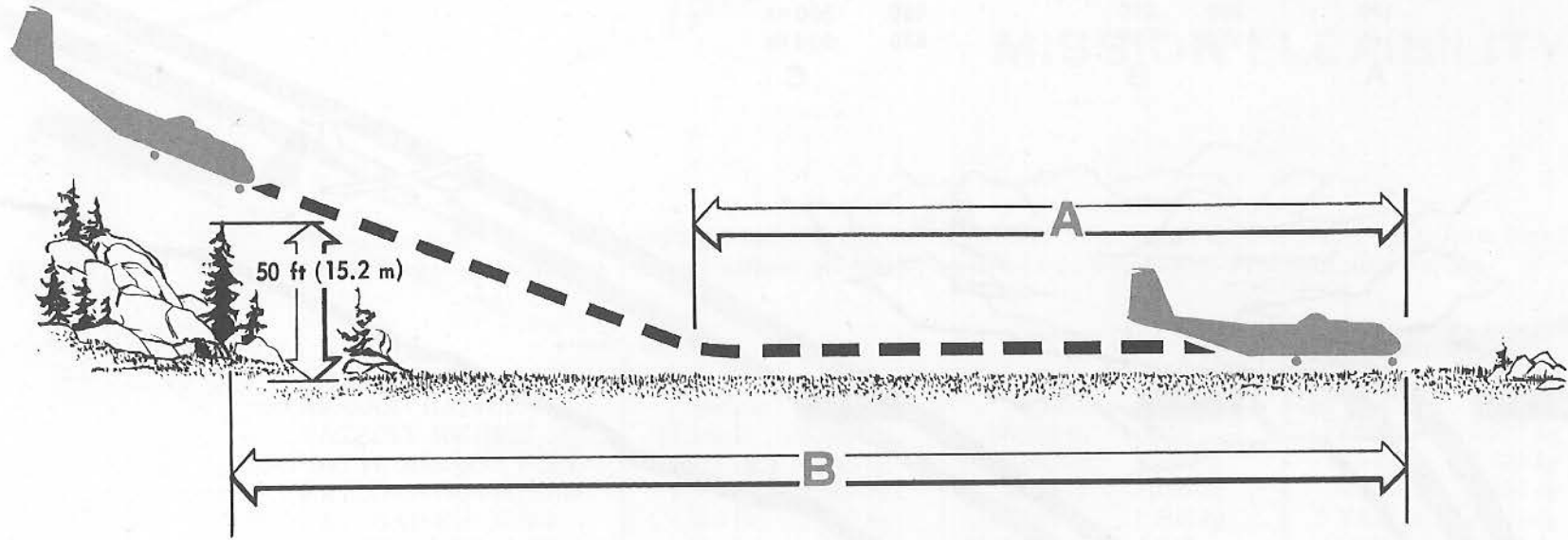

CONDITIONS	A ROLL	B TOTAL FROM OBSTACLE	DESCENT GRADIENT
ISA,ZERO WIND	505 ft (153.9 m)	1000 ft (304.8 m)	17.0%
ISA,8 KNOT WIND	390 ft (118.9 m)	820 ft (249.9 m)	19.1%

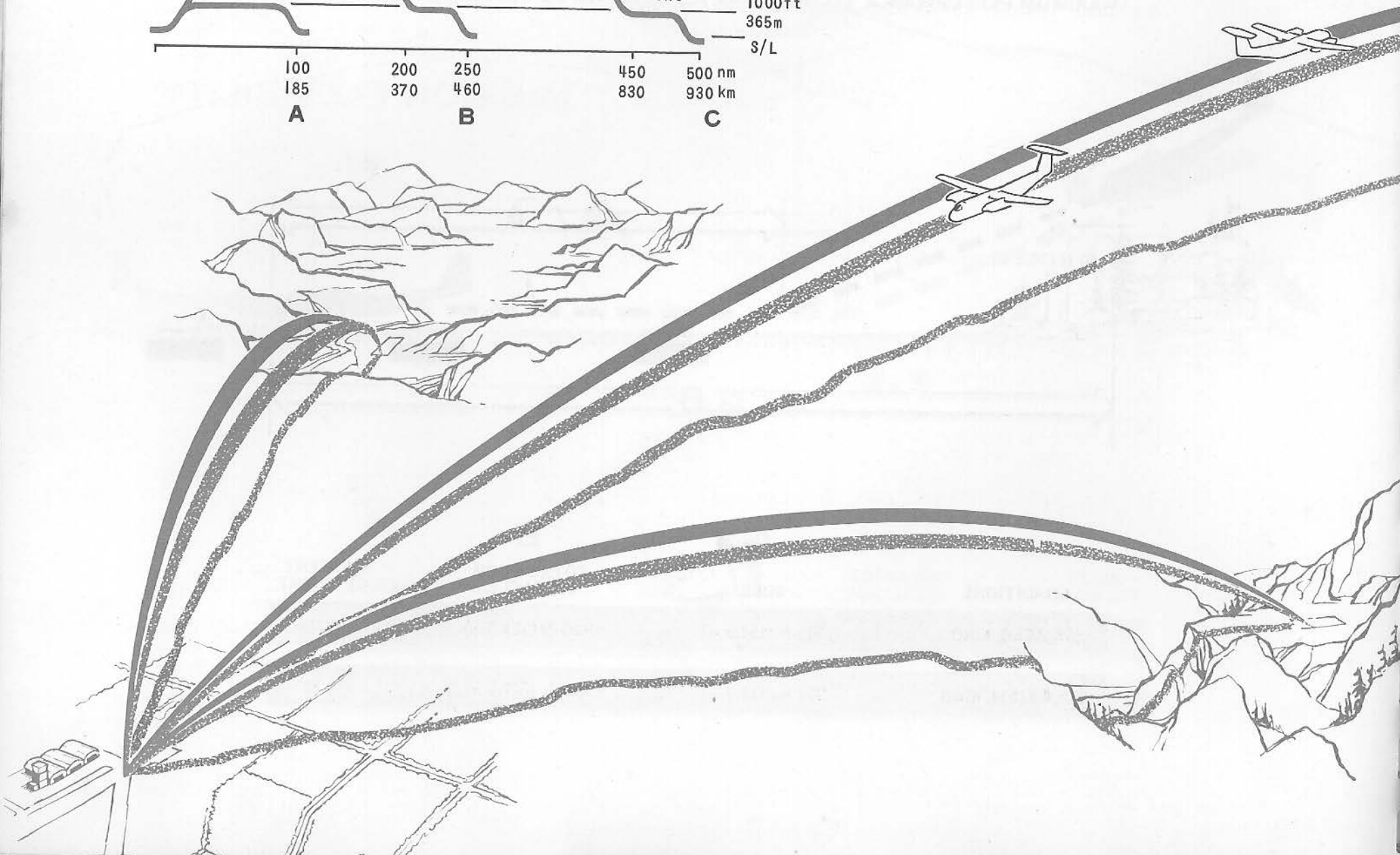
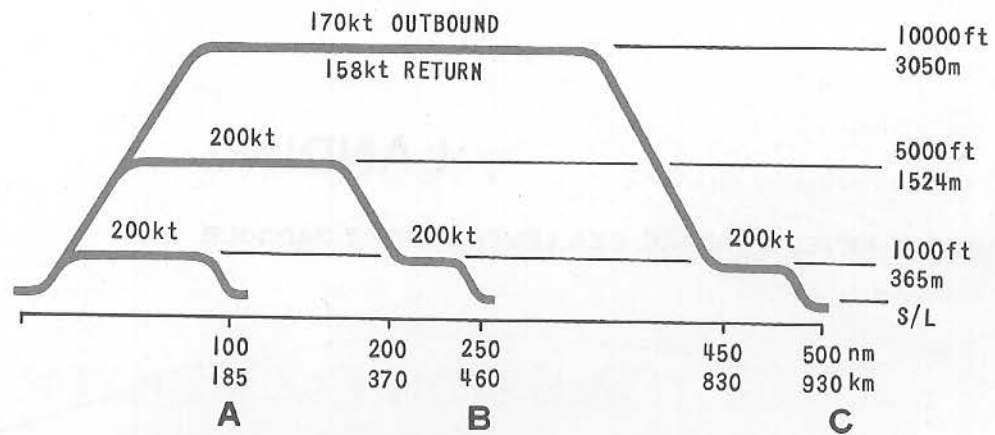

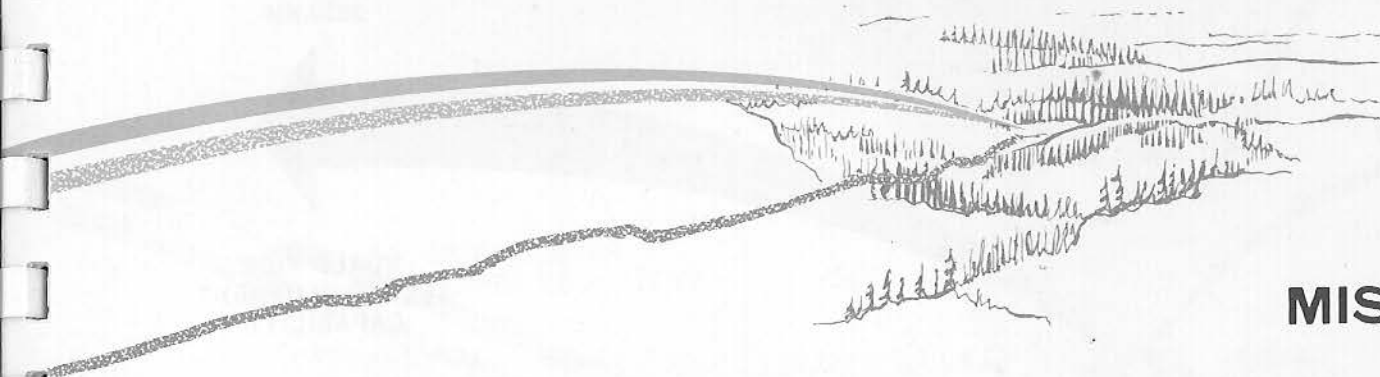

## MISSION FLEXIBILITY

These examples show the operational capability of the CARIBOU II in supplying military materiel from bases having prepared runways to outposts without prepared runways, cargo handling equipment or fuel supplies.

	<b>A</b> 100 nm <i>185 km</i>		<b>B</b> 250 nm <i>460 km</i>		<b>C</b> 500 nm <i>930 km</i>	
MISSION RADIUS	100 nm	█	250 nm	█	500 nm	█
TAKEOFF WEIGHT	35,246 lb	<i>15,988 kg</i>	36,599 lb	<i>16,601 kg</i>	38,000 lb	<i>17,237 kg</i>
TOTAL MISSION FUEL	2,741 lb	<i>1,243 kg</i>	5,687 lb	<i>2,580 kg</i>	8,646 lb	<i>3,922 kg</i>
PAYLOAD OUTBOUND	9,961 lb	<i>4,518 kg</i>	8,369 lb	<i>3,796 kg</i>	6,804 lb	<i>3,086 kg</i>
PAYLOAD INBOUND	4,980 lb	<i>2,259 kg</i>	4,184 lb	<i>1,898 kg</i>	3,402 lb	<i>1,543 kg</i>
TAKEOFF DISTANCE	1,060 ft	<i>323 m</i>	1,140 ft	<i>347 m</i>	1,225 ft	<i>373 m</i>
LANDING DISTANCE	1,000 ft	<i>305 m</i>	1,000 ft	<i>305 m</i>	1,000 ft	<i>305 m</i>
TOTAL MISSION TIME	1.44 hr		2.96 hr		6.44 hr	

Cruising speeds and heights: As shown  
 Operational empty weight: 22,550 lb (10,229 kg)  
 Fuel reserves: 10 percent of initial fuel  
 Conditions: International Standard Atmosphere,  
 Zero Wind

Refuelling: No refuelling at mission midpoint  
 Handling: Cargo unloading rate at outpost calculated  
 at 1500 lb/min (680 kg/min)  
 Payload: Based upon STOL landing weight of 34,000 lb  
 (15,422 kg) at mission midpoint

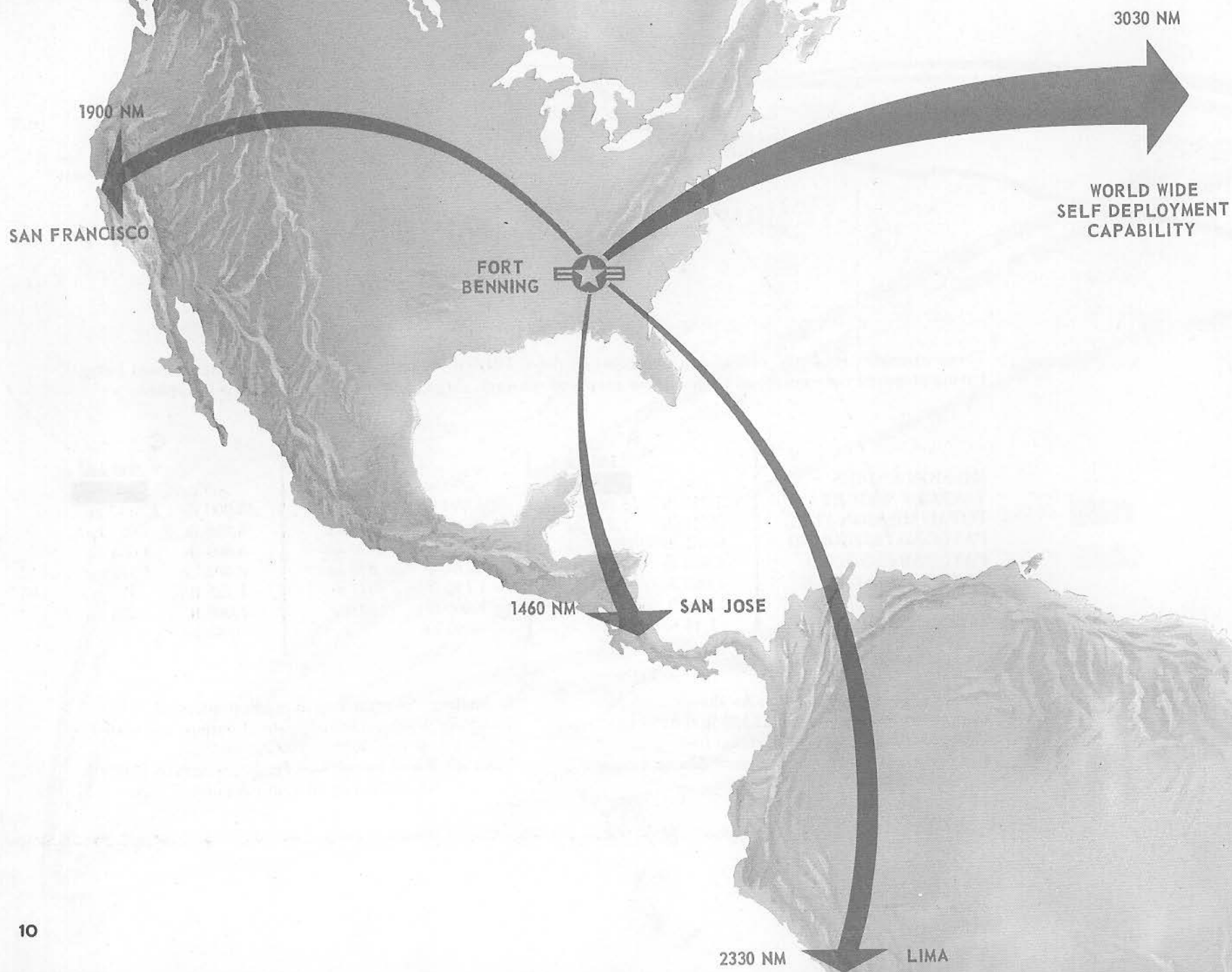

# DEPLOYMENT CAPABILITY

These examples show the self deployment capability of the CARIBOU II in four modes. With auxiliary fuel tanks installed in the cargo compartment, this 3,000 nautical mile range permits the aircraft to be self deployed anywhere in the world.

	A	B	C	D
OXYGEN, FERRY TANKS AND OVERSEA EQUIPMENT	0 lb 0 kg	1,000 lb 454 kg	1,500 lb 680 kg	1,500 lb 680 kg
OPERATIONAL WEIGHT EMPTY	22,550 lb 10,229 kg	22,550 lb 10,229 kg	22,550 lb 10,229 kg	22,550 lb 10,229 kg
TOTAL FUEL	11,000 lb 4,990 kg	11,000 lb 4,990 kg	17,950 lb 8,142 kg	17,950 lb 8,142 kg
TAKEOFF WEIGHT	33,550 lb 15,218 kg	34,550 lb 15,672 kg	42,000 lb 19,051 kg	42,000 lb 19,051 kg

LONG RANGE SPEED, INTERNATIONAL STANDARD ATMOSPHERE, ZERO WIND,  
FUEL ALLOWANCES AND RESERVES TO MIL - C - 5011A

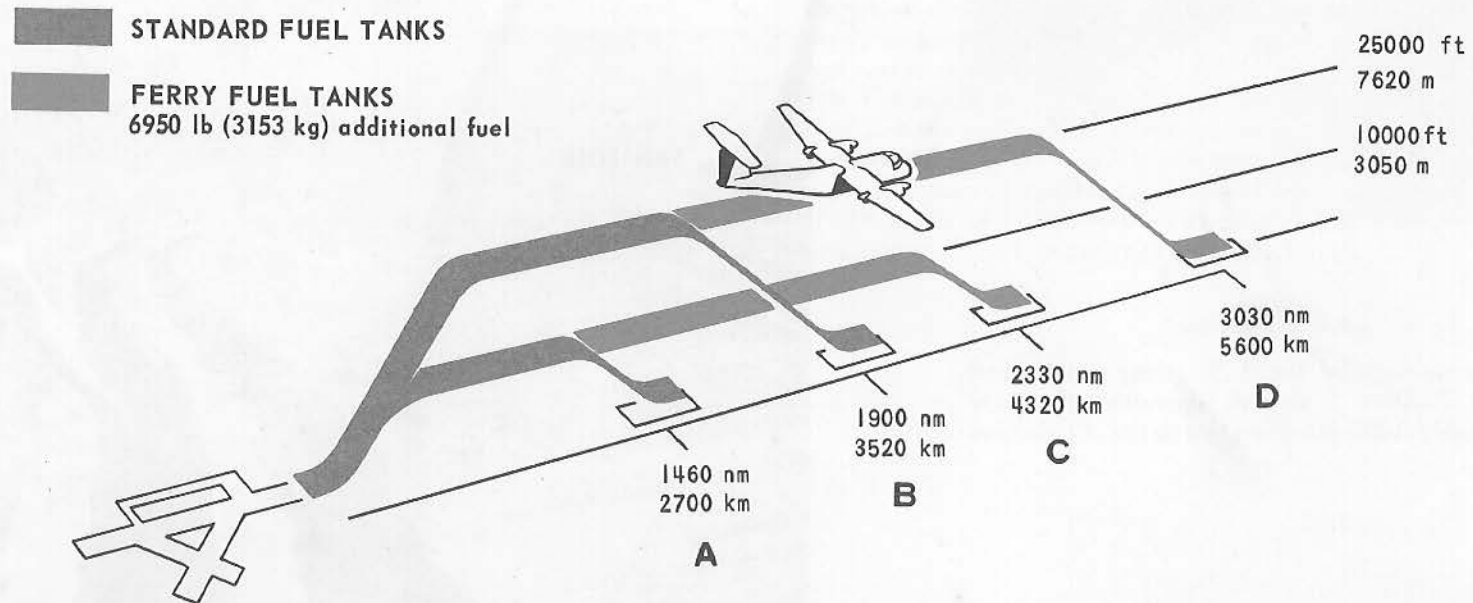





The Caribou I aircraft has successfully operated in the soft sands of the Saudi Arabian desert

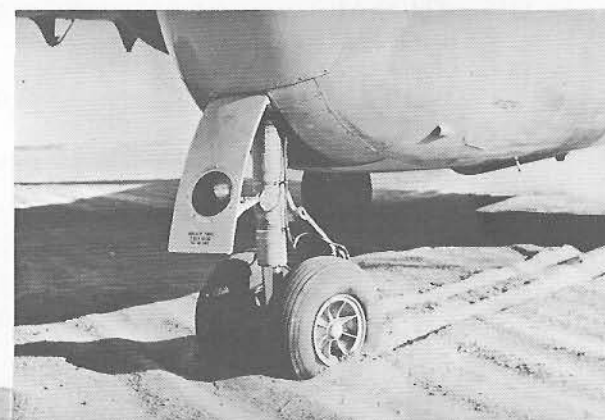

Tests conducted by the U.S. Army established that the Caribou I aircraft operates effectively out of muddy fields ploughed to a depth of 14 inches (35 cm)



## UTILITY

The Caribou II's cargo capability effectively spans the wide spectrum of military transport requirements, since the 11,450 lb. of cargo it carries includes 88% of all vehicles and weapons normally allocated to an Army Division.

As a personnel carrier the Caribou II can be fitted with bench-type seats which will carry 34 fully equipped troops. This seating arrangement allows rapid embarkation and off-loading of combat troops through the large rear loading door. The cabin is insulated and upholstered, well heated and ventilated, and fitted with the facilities necessary to ensure comfort on long stage lengths.

The aircraft's unique "go anywhere" characteristics make it ideally suited for air ambulance duties. Again, the rear loading door permits easy and effective access in this role.

Ramp extensions, which are normally carried in the aircraft, facilitate effective ground-to-aircraft loading of cargo and also allow wheeled vehicles to drive in under their own power.

Stowable roller conveyor and side guidance system will be installed permitting the use of palletized cargo. Composite cargo presents no problems as seats fold against the side walls, giving free access to the tie-down points, permitting personnel and cargo to be carried in any desired combination.

The low-speed characteristics of the Caribou II make it an outstanding aircraft for precision aerial drop work. Flying characteristics are unaffected with the rear loading door open. Using either the loading door or the side doors at the rear of the cabin, paratroops can clear the aircraft quickly and safely.

Excellent visibility, manoeuvrability and low-speed safety make the Caribou II an ideal aircraft for search and rescue operations.

The Caribou II has a speed range of approximately 4 to 1, and combines its excellent low speed characteristics with a fast and economical cruising speed. Normal transport functions are carried out at a speed of 200 knots at 10,000 ft. over a range of 480 miles, resulting in a work capacity of 1,000 ton knots.

# CARGO LOADING

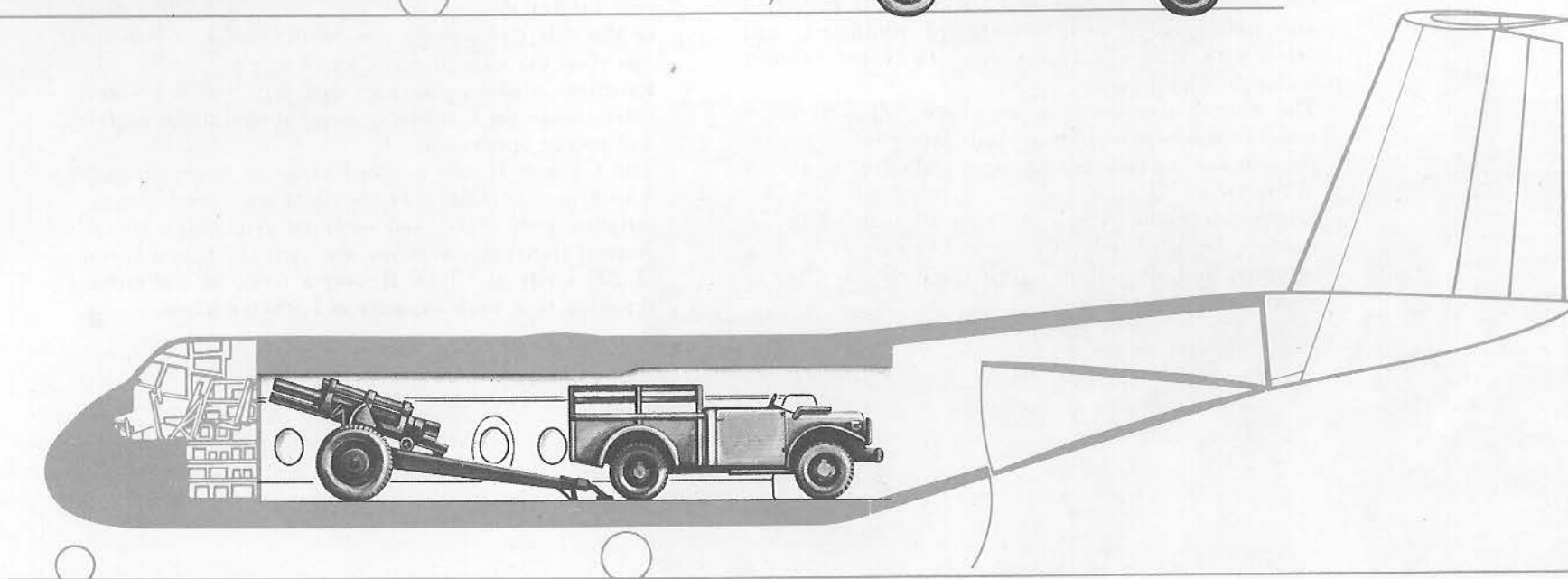
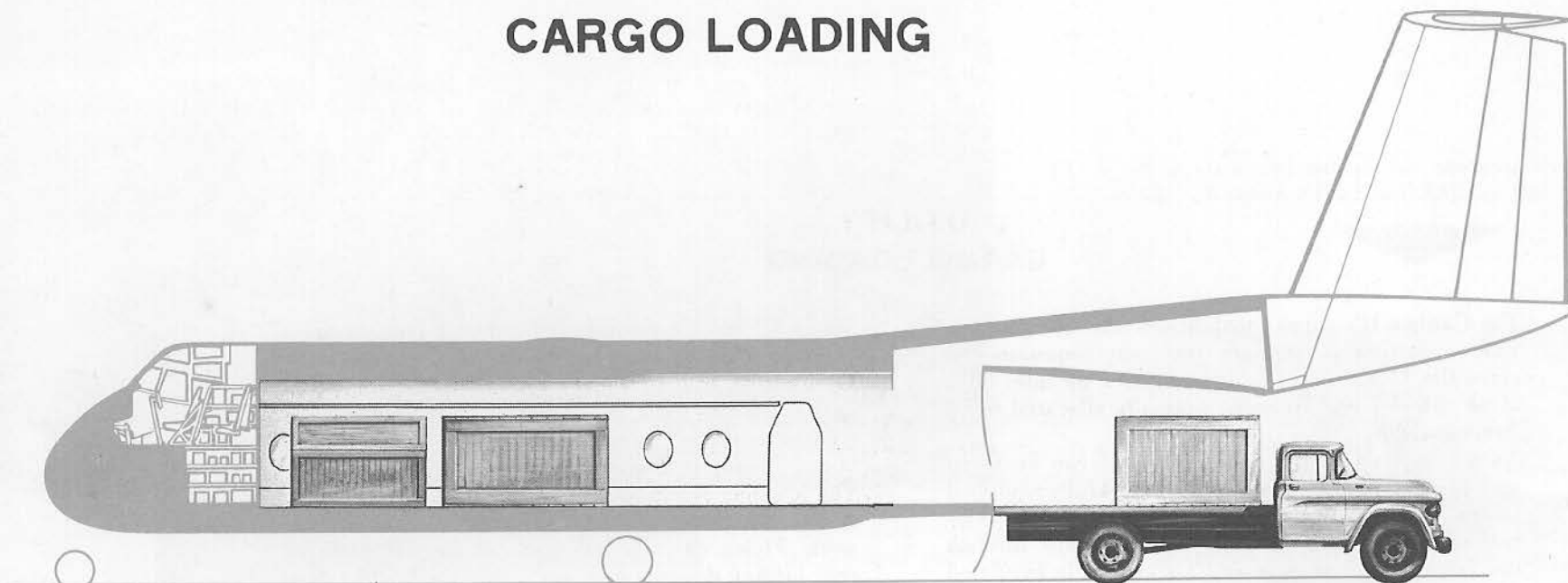

## CARGO LOADING

The high empennage allows ample clearance for trucks to back into the opening beneath the rear fuselage when the rear loading door is open. The ramp is electrically adjustable to suit various truck loading heights, in order to facilitate the movement of stores from truck to aircraft or vice versa. The ramp extensions carried in the aircraft, permit vehicles to drive in under their own power, and assist the manhandling of wheeled equipment – artillery, helicopters, etc., into the cabin. The ramps can also be used when no platform is available and loading has to be carried out from ground level. The cabin is equipped with 5,000 lb. capacity tie-downs on a 20 in. grid over the whole floor area, plus 10,000 lb. tie-downs at eight points. This provides for quick and effective lashing of cargo and equipment.

The Caribou II is able to transport by air the following U.S. Army equipment:

Honest John Missile, on trailer	XM 561 1¼ ton truck
Lacrosse Missile, on trailer, with ¼-ton truck	XM 104 SP 105 mm Howitzer
Nike-Ajax Missile, in containers	XM 102 105 mm Howitzer
Nike-Hercules Missile components, in containers	Lance Missile
XM 571 1 ton carrier	Palletized Cargo
¾ ton truck	Pershing Missile Resupply System

Quick loading and short turn-around time is assured with the large electrically-operated rear loading door and ramp, permitting rapid loading and unloading of the aircraft on the ground. Both door and ramp may be opened in flight for parachuting men and equipment. Provision has been made in the forward cabin for the installation of a winch to assist cargo handling.

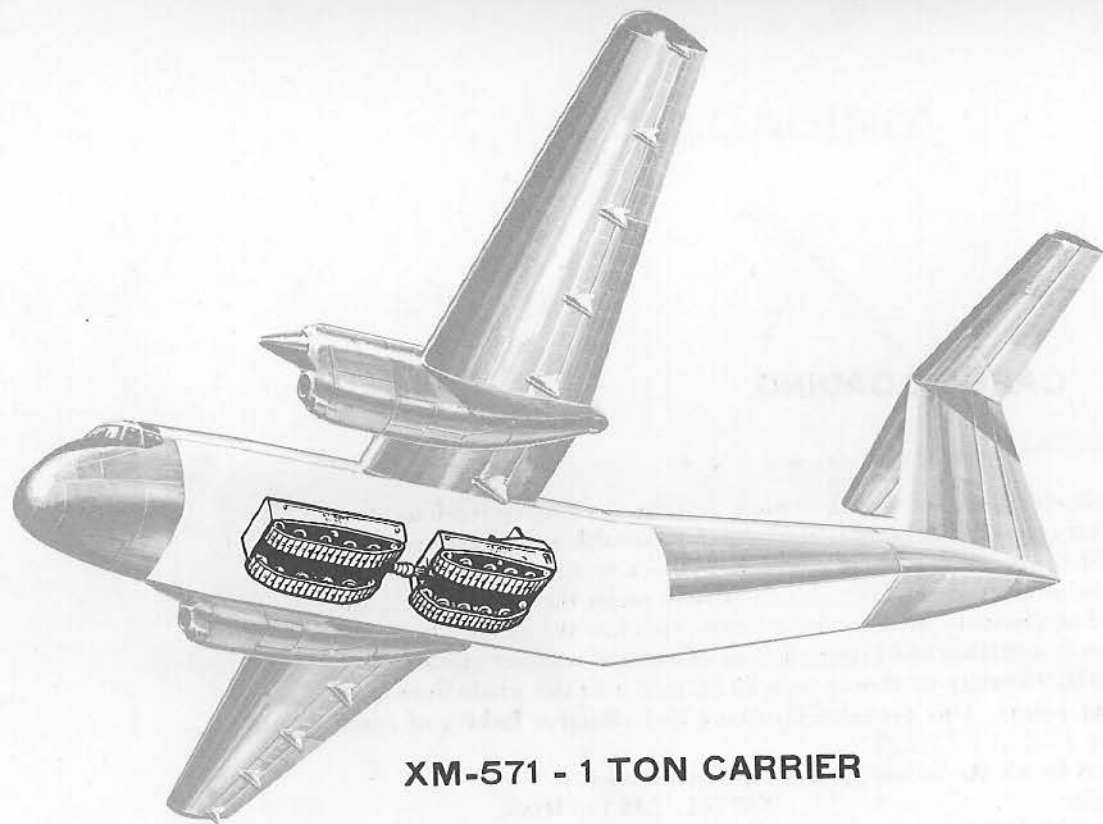

**XM-571 - 1 TON CARRIER**

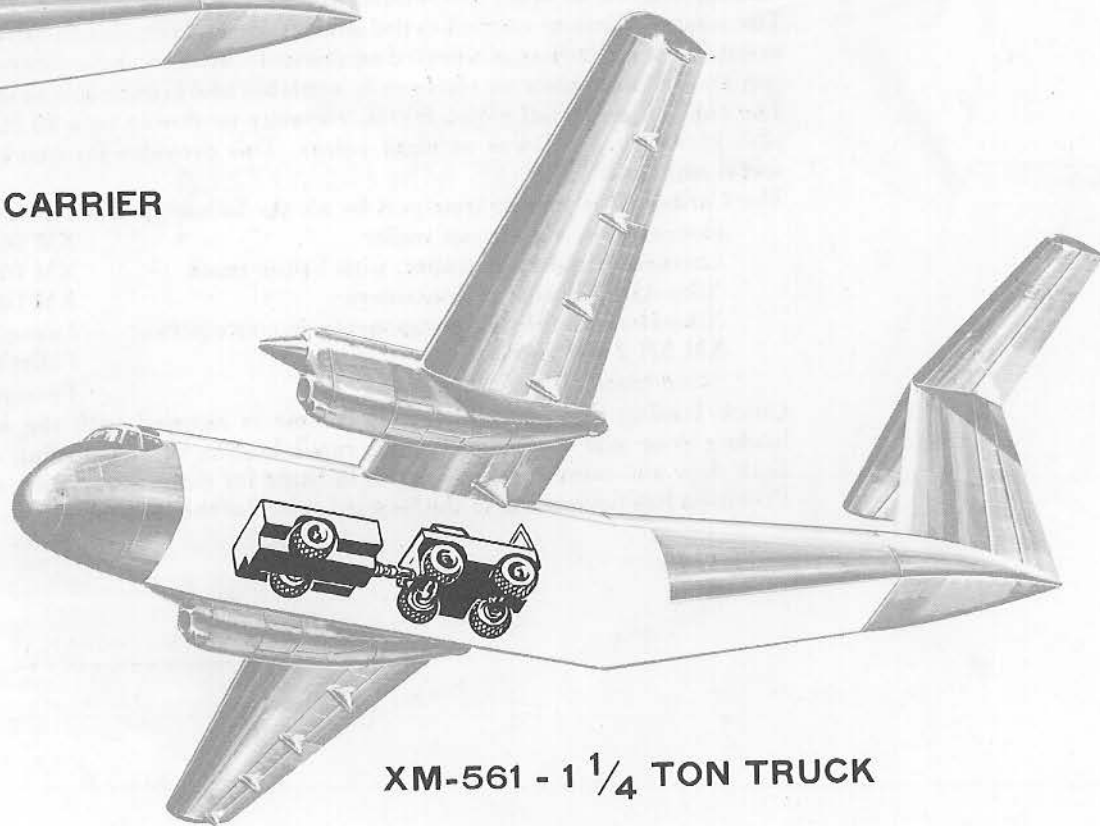

**XM-561 - 1 1/4 TON TRUCK**

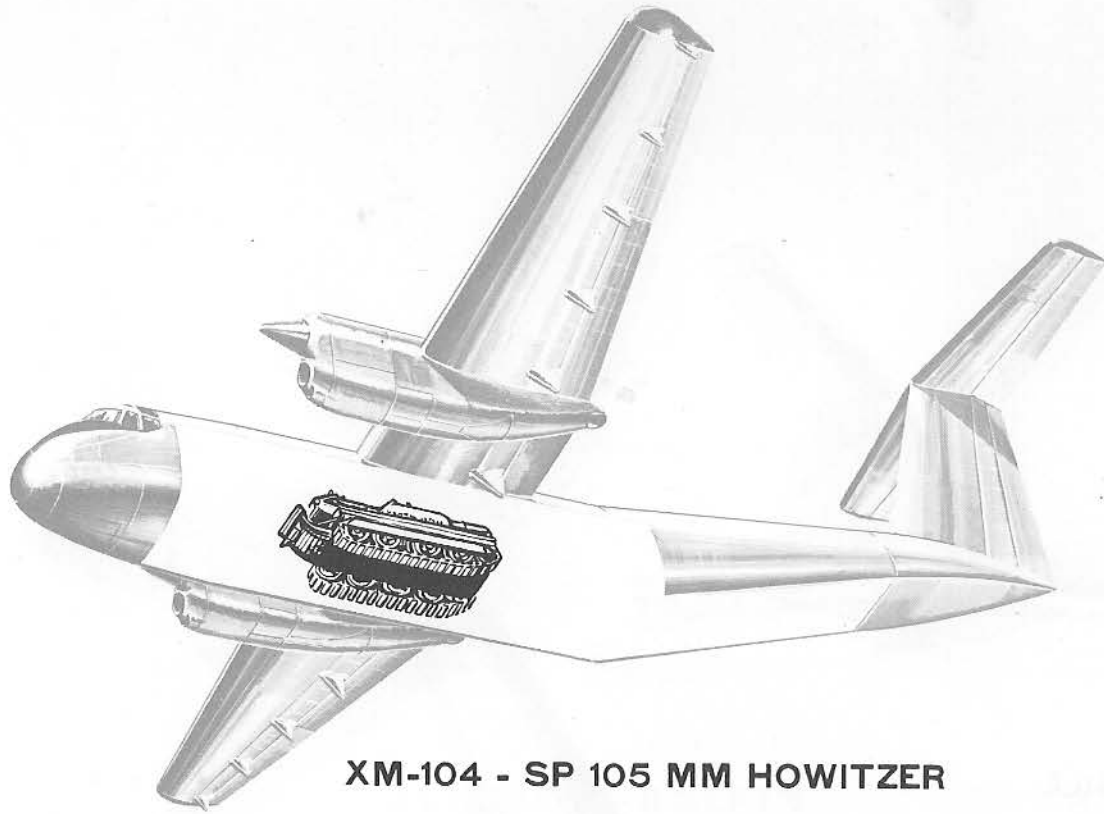

**XM-104 - SP 105 MM HOWITZER**

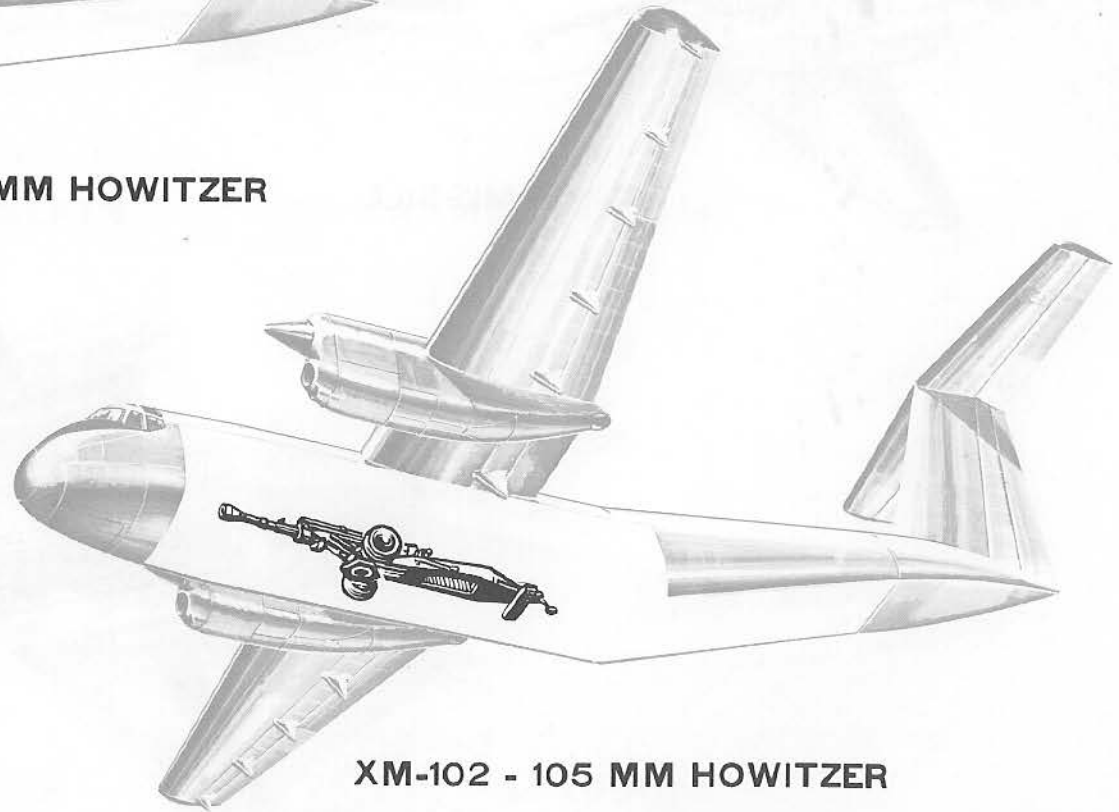

**XM-102 - 105 MM HOWITZER**

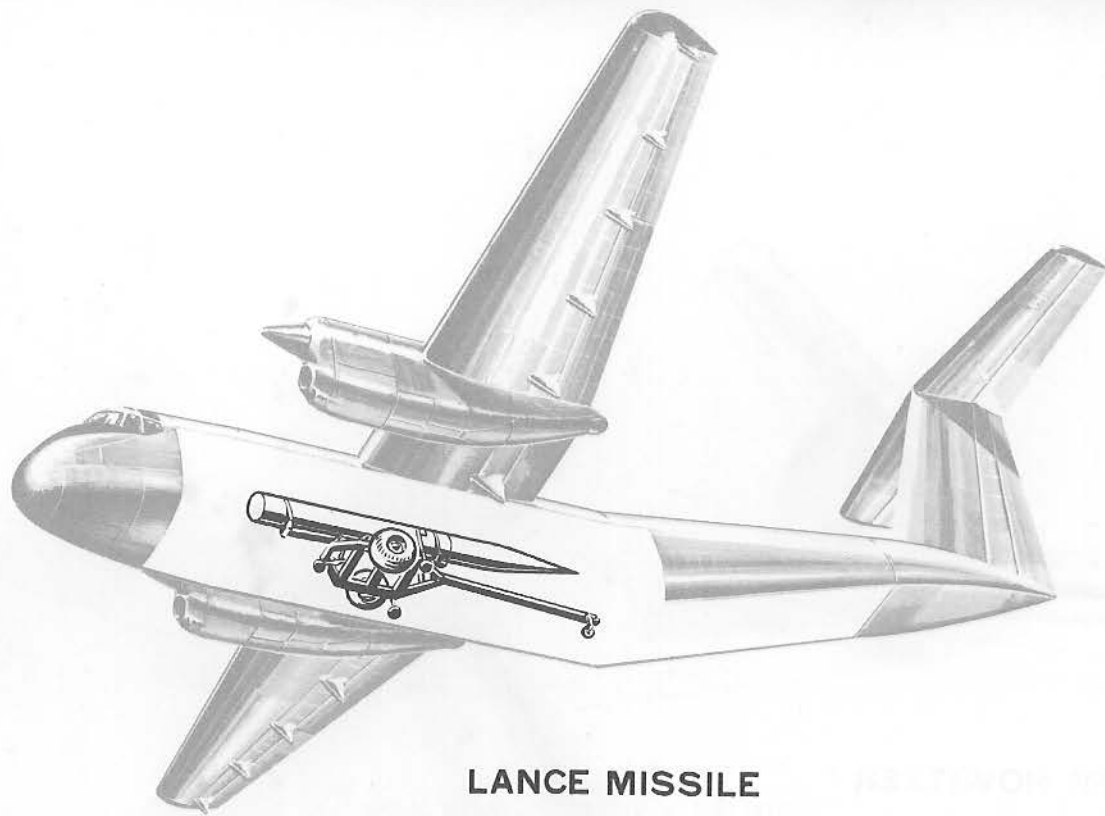

**LANCE MISSILE**

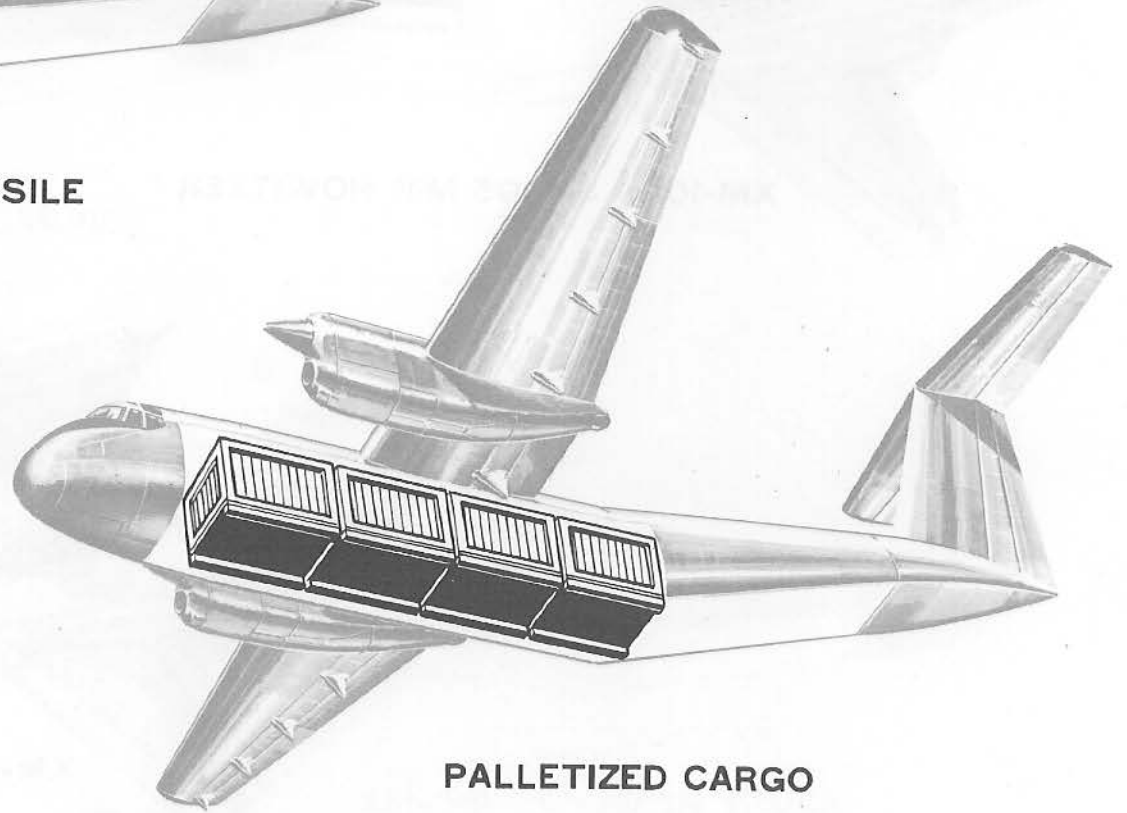

**PALLETIZED CARGO**

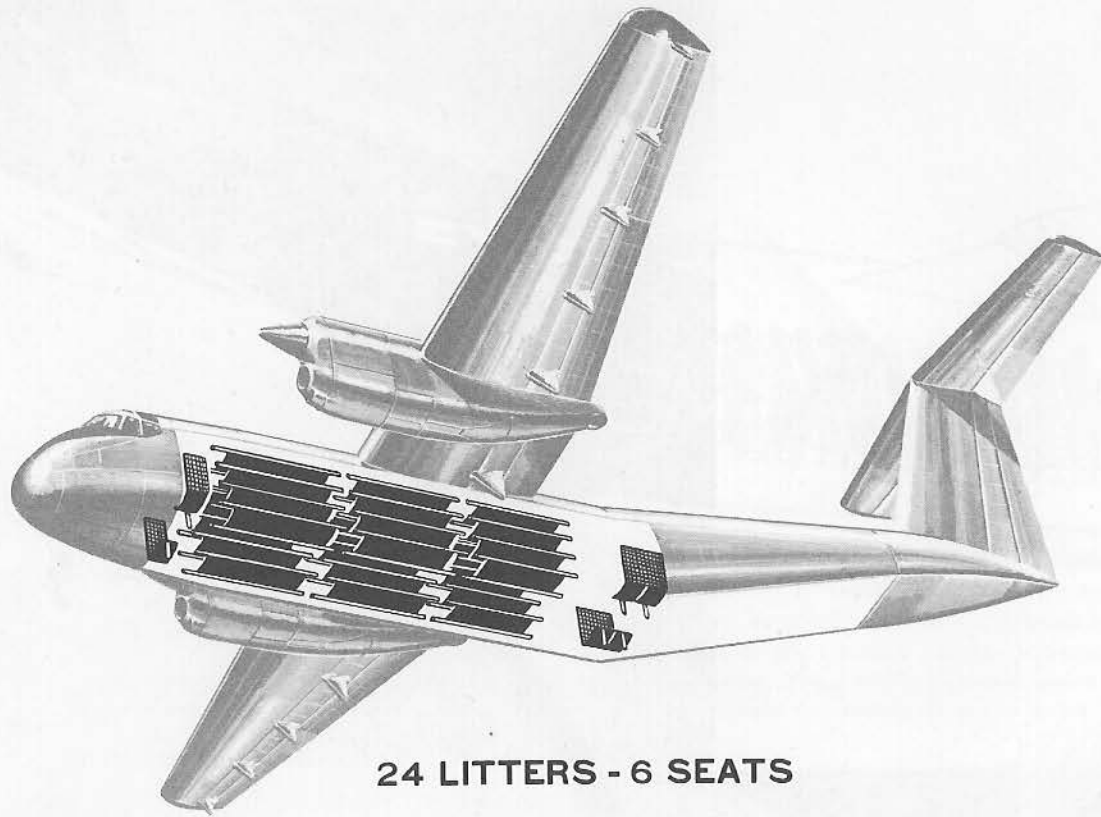

**24 LITTERS - 6 SEATS**

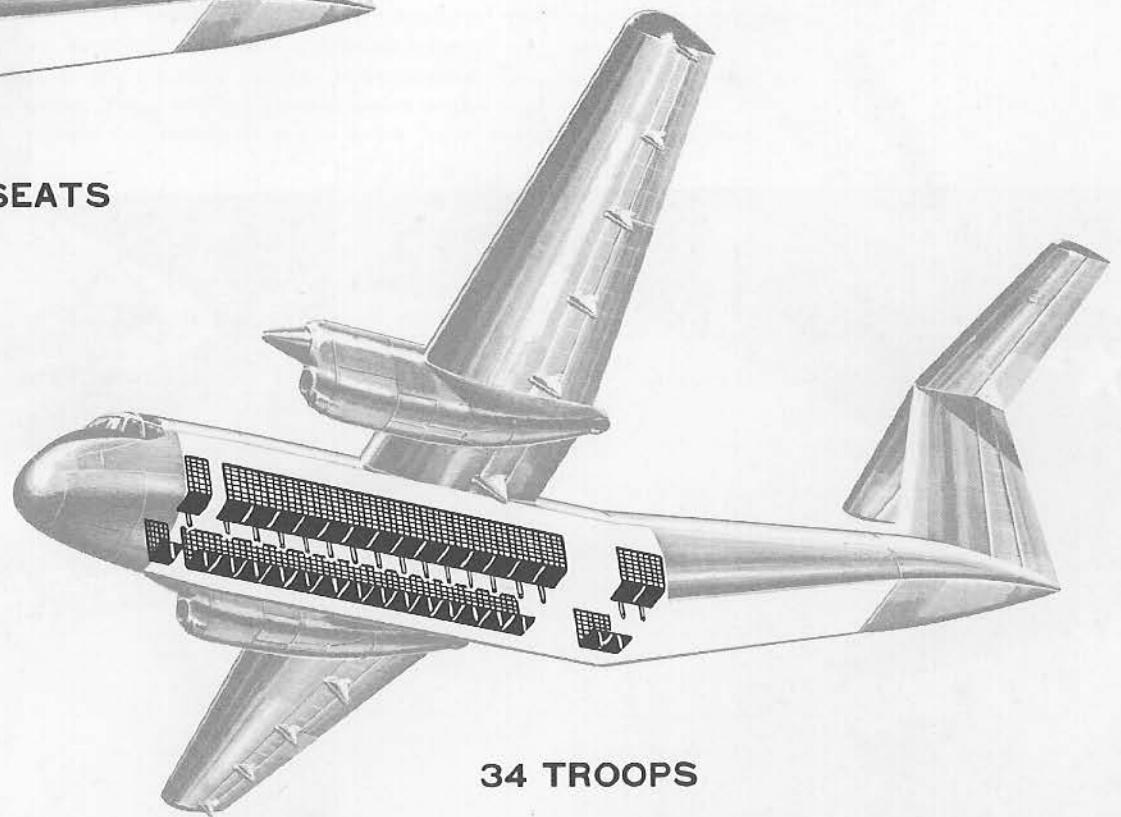

**34 TROOPS**



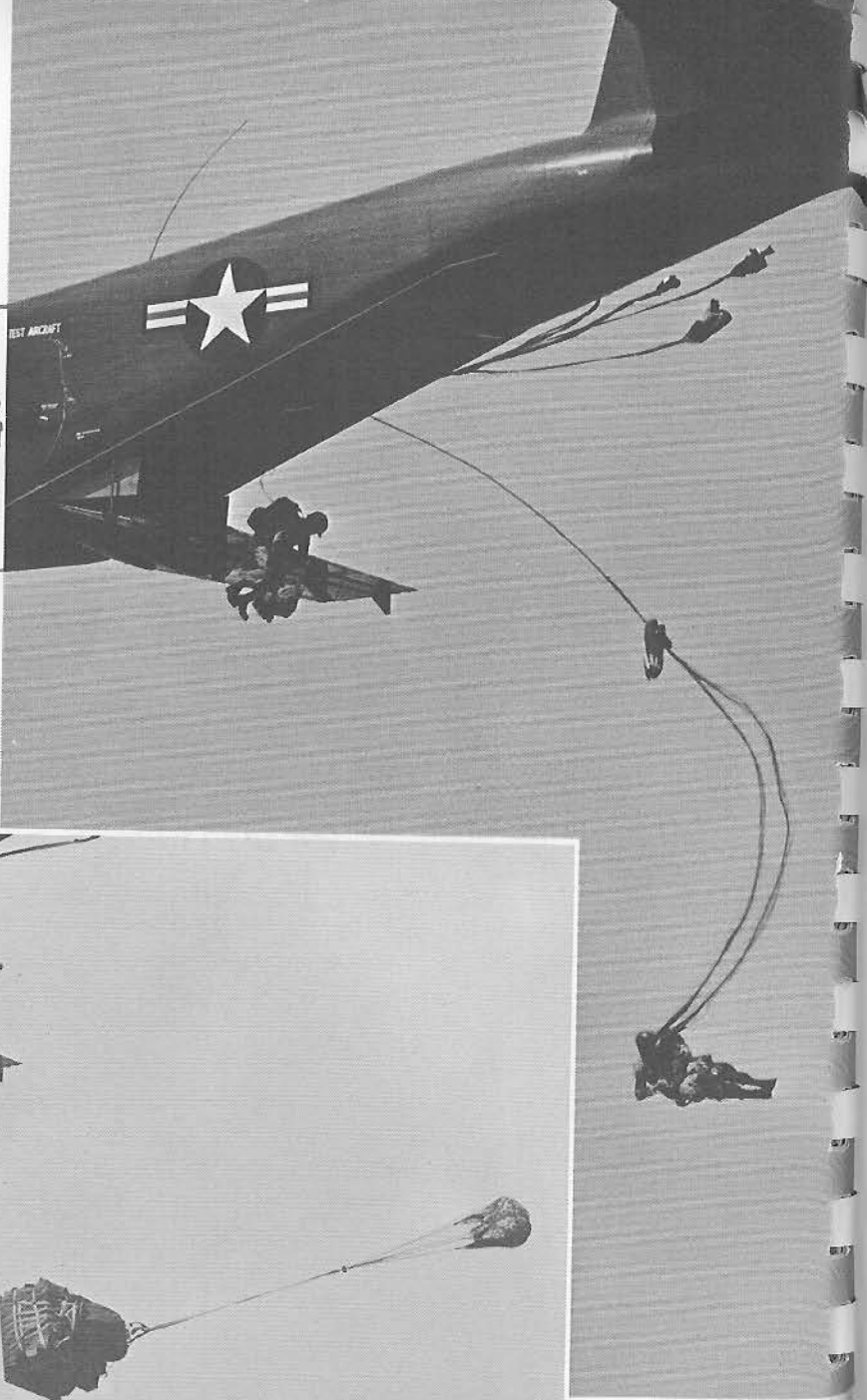
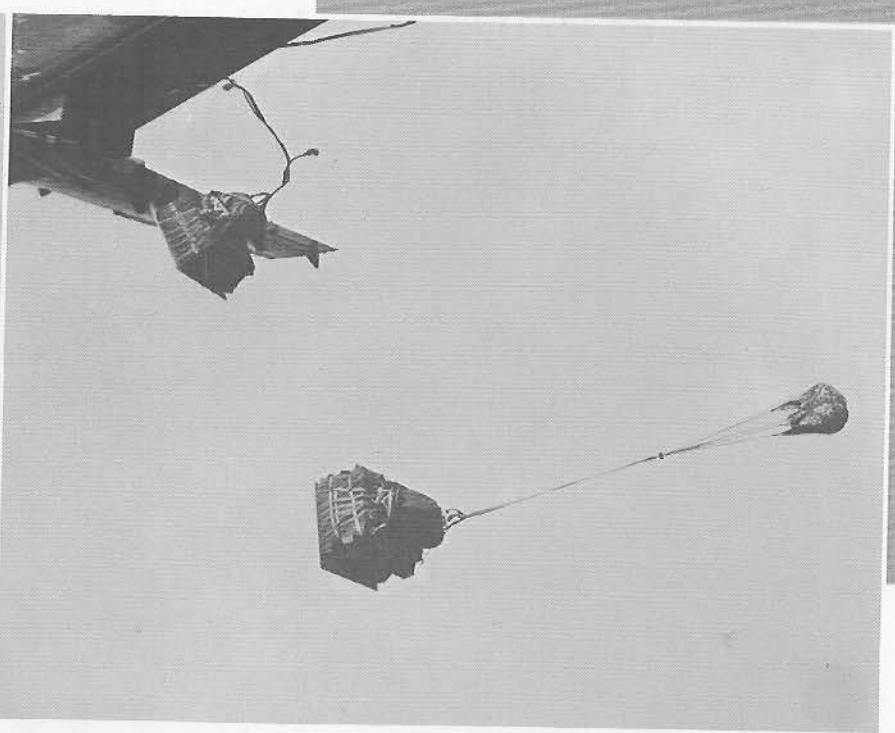
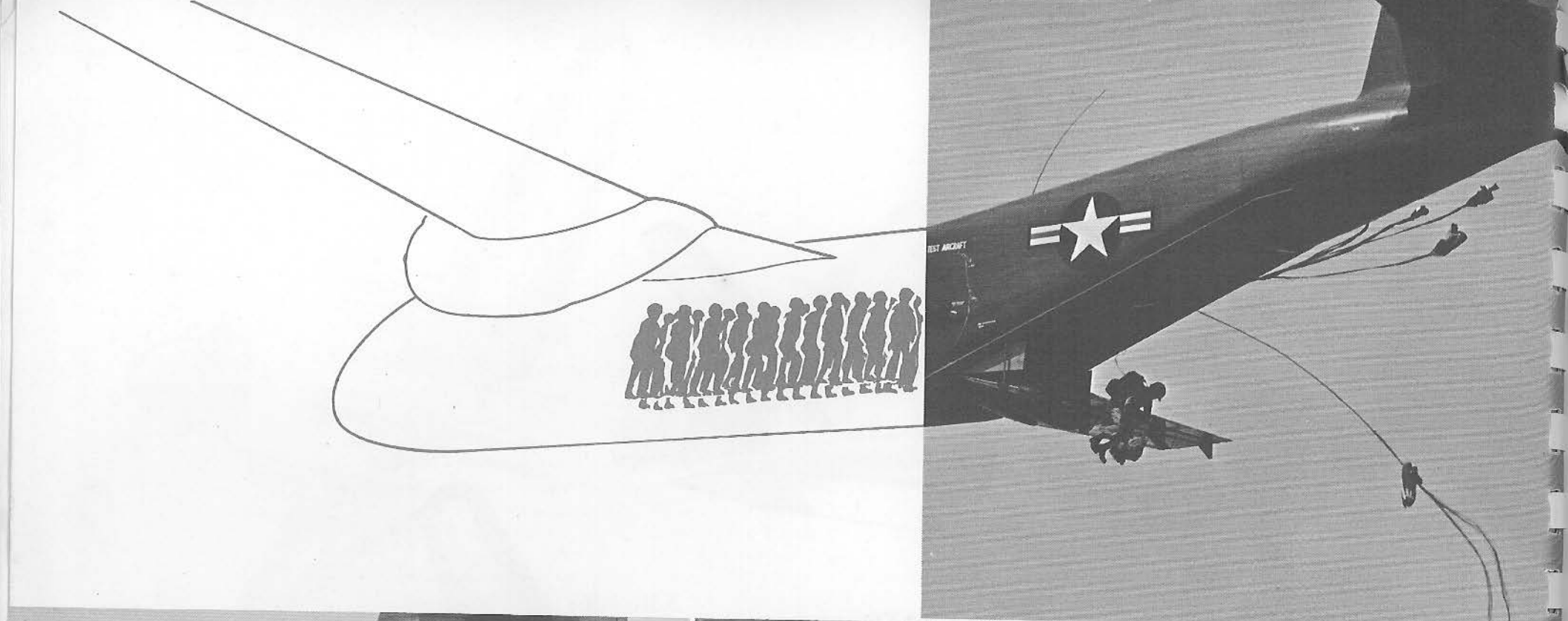

## TROOP-CARRYING AND SUPPLY-DROPPING

When used as a troop transport, 34 fully equipped troops or 28 paratroops can be carried on fabric bench-type seats. The troops can either be landed in the combat zone and deployed rapidly through the rear loading doors, or they may be parachuted into a critical area.

U.S. Army tests shown opposite, with the Caribou I have demonstrated effective procedures for a rapid and safe delivery of paratroops, using either the side doors or the rear loading door.

Easily installed litter kits are available to provide as many as 24 litters for air ambulance duties, with seats for six attendants.

Official tests of the U.S. Army Airborne and Electronics Board have demonstrated the suitability of the Caribou I for aerial delivery by parachute of a wide variety of military loads. Drops were made using standard air delivery techniques, at airspeeds of 80 to 110 knots.

Single dropped loads from the Caribou I included the following:

one M38 "Jeep"	two M274 "Army Mules"	one M170 ambulance
twelve drums of fuel	one mountain howitzer	

These Caribou I loads also included platforms 68 x 144 in. loaded to heights of 64 in. and weighing 6,200 lb.

The Caribou II will provide equally suitable characteristics, with load capacity for the standard 88 inch width pallets of unit weights up to 7,500 lb.

## RELIABILITY AND EASE OF MAINTENANCE

The structure and equipment of the Caribou II are designed for simplicity, reliability and ease of maintenance. These factors have been thoroughly developed and demonstrated in the Beaver, Otter, and Caribou I airplanes which de Havilland have supplied throughout the world during the past fifteen years.

These airplanes have all been built for the same principal function: the transportation of cargo and personnel to and from short and poorly-surfaced landing areas. Each design has accumulated the experience of its predecessors and, as this experience becomes progressively more intensive, its effect on subsequent designs becomes more valuable.

Many of the unusual features of the Caribou II have been developed during the design and service experience of the Caribou I, so that their reliability and ease of maintenance have already been established; these include the following systems and components:

High-lift wing flap	Power-operated cargo loading ramp
Two-stage landing-gear shock-absorbers	Facilities for cargo air-dropping

Under a contract between General Electric and the United States Navy, the General Electric T-64 engine is being subjected to one of the most extensive test programs ever planned. This program requires 10,000 hours of running on test stands, and 200 hours of flight testing. The flight testing was accomplished in a Caribou I airplane: more than 250 engine hours in flight were completed by early 1963.



# DESIGN CHARACTERISTICS

## STRUCTURE

In keeping with the utility characteristics of the aircraft, every effort has been made to keep the Caribou II simple, rugged and easy to maintain. Standard materials, processes and equipment to U.S. MIL requirements, have been used throughout to ensure effective field maintenance with a minimum of logistic support and without special skills. All systems are designed on "fail-safe" principles or are covered by large design factors, and have shown excellent reliability under extreme operating conditions. The United States Army, working with production models of the piston-engined Caribou I, has established the ability of the aircraft to work on an operational basis for fifteen hours a day.

The design of the Caribou II has been carried out to

the requirements of CAR-4b, and structural load factors are in excess of those specified. The stability, manoeuvrability and control of this type of airplane have been well demonstrated in the 40,000 hours of flying which have already been experienced with the Caribou I.

The cabin is especially rugged. Heavy frames and a multiple reinforced floor structure allow heavy concentrated loads to be carried and provide a large reserve strength for emergency landing conditions.

The structure also provides for a uniform cargo loading of 300 lb. per sq. ft. The cabin has a cargo density factor of 7.46 lb. per cu. ft. when carrying a capacity payload, and is seldom volume-limited.

## SYSTEMS

The control and equipment systems of the Caribou II have been designed for simplicity, reliability and ease of access. Wherever appropriate, the requirements of U.S. MIL specifications have been met.

The flight and powerplant controls are pushrods and cables passing through the upper part of the fuselage and the leading-edge of the wing. Access to these is obtained through openings in the cabin ceilings, without removal of structural components, and by hinged nose-sections on the wing. Hydraulic and electric components are mainly located in the forward fuselage, with charging and testing facilities accessible from the ground or from the cockpit, and with piping and wiring runs above the ceiling of the cabin.

Electronic components are mounted in racks in the rear of the cockpit, and are accessible during flight.

Heating, cooling and ventilating systems powered by either bleed air from the engines or by auxiliary power are provided for both the cockpit and cabin areas. Under floor ducting with outlets at floor level are provided in the large cabin.

De-icing of the leading edges of the wing and tailplane is provided by inflatable rubber boots operated by bleed air from the engines.

The engine air intakes are protected against icing by the engine bleed air system. The propellers have electric de-icing.

The engine starting system permits starts to be made without external power supply, by using either bleed air from the engine or the auxiliary power unit.

Powerplant fire-extinguishing is provided in the compressor and combustion zones in the nacelles. Two chargers of freon are available, which may be directed to either powerplant.

## PROPULSION GROUP

The propulsion group comprises two General Electric T-64 turboprop engines driving Hamilton Standard 63E60 reversing propellers.

The T-64 is a highly refined free turbine engine which reflects General Electric's considerable experience with turbine engines in this power range. The free turbine concept is particularly suitable for an aircraft of this type, since it permits a wide range of power for relatively constant propeller rpm and has the ability to accelerate this engine power very rapidly.

Sponsored by the U.S. Navy, the T-64 has exceeded 10,000 hours running and is already undertaking its military qualification tests.

The Hamilton Standard propeller has an integral oil system. It is designed to operate with the T-64 and has blades tailored to the specific requirements of the Caribou II.

Easy access to the engine is provided through readily removable nacelle panels. The engine is carried on four pickup points and may be quickly removed using ground equipment.

## LANDING GEAR

The landing gear has been designed to meet the requirements of operations on to and from rough unprepared fields: it has a high energy absorption rate of up to 13 ft/sec permitting very steep angles of approach to be accomplished with maximum safety.

Two-stage shocklegs are used on both main and nose gears to provide a stable platform, even when loading and unloading the heaviest equipment. The design of the landing gear is such that wheel ski units can be fitted when required.

The steerable nose wheel and power-operated brakes, combined with good flotation, large rolling radius tires and the high clearance of the fuselage and propellers, give the Caribou excellent taxiing characteristics, permitting operations insensitive to local terrain conditions.

## FLIGHT COMPARTMENT

The arrangement of the flight compartment of the Caribou II is by design similar to that of the Caribou I shown below.

The flight deck is well above cabin level and accommodates two pilots and a crew chief beneath a transparent canopy which provides virtually unobstructed all-around vision.

The "birdproof" windshield is electrically heated and ensures effective anti-icing. Draft proof, clear-vision windows by the side of each pilot provide adequate visibility under all conditions. Each pilot has a full flight panel. Engine instruments and an emergency systems panel are centrally located, and accessible to both pilots. A sliding console between the pilots provides easy access to the radio controls, and can be stowed away beneath the instrument panel when not in use. The spaciousness of the flight compartment is increased further by an overhead engine control console, with hanging throttle, pitch, mixture, flap and landing gear levers. All the radio equipment controls and presentations and the circuit-breaker panels are located in the flight compartment within easy reach of the pilots.

Two emergency escape hatches are provided, one in the roof and the other, a parachute exit, in the floor.

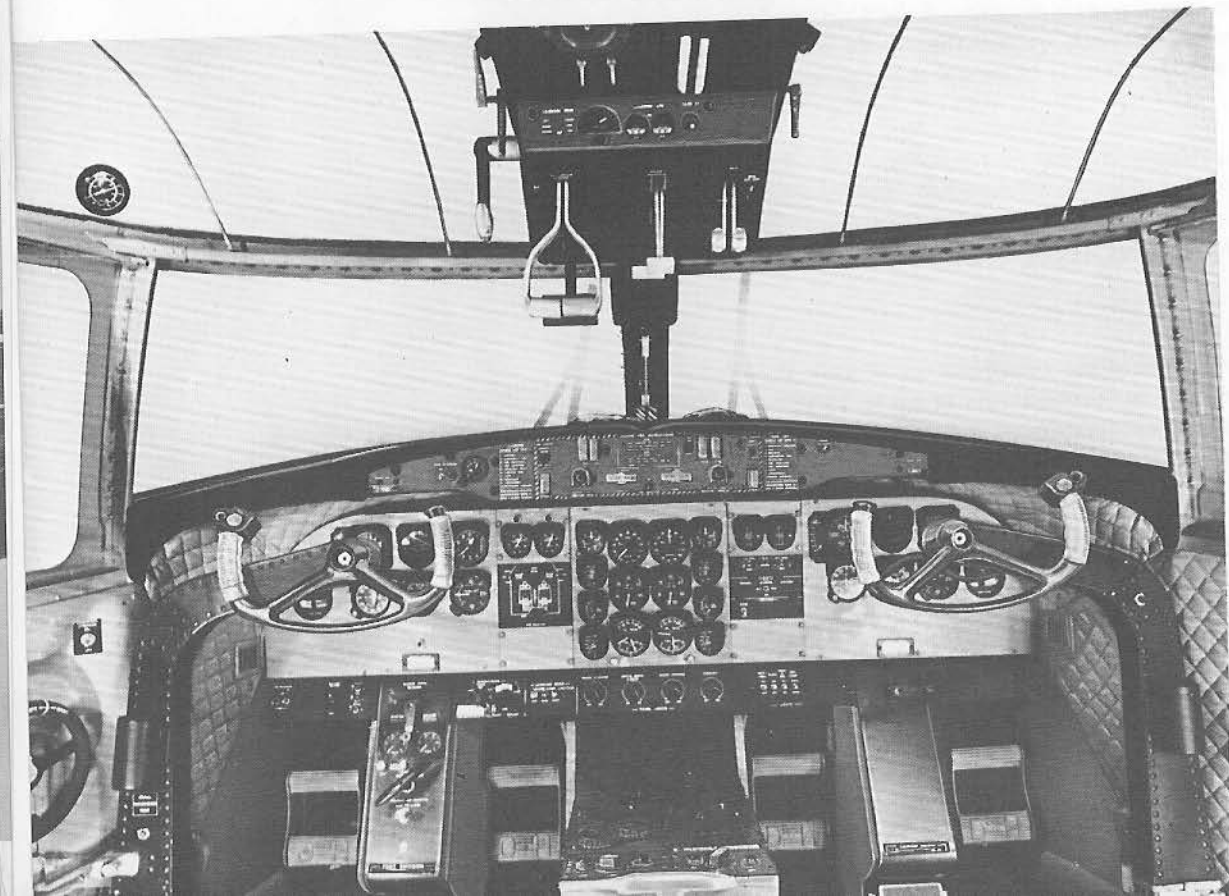



## PERFORMANCE CHARACTERISTICS

The performance information in this section is based on Flight Test results of the Caribou I airplane, engine data supplied by the General Electric Company for the T-64 engine, and propeller data supplied by Hamilton Standard for the T-64 application.

Take-off power refers to power available on a five minute rating. Military power is on a thirty-minute rating, and Normal Rated Power is the maximum permitted for continuous use. All powers used are current ratings and do not reflect the engine growth potential available in the time span being considered. Full allowances have been made for engine installation losses. Payloads are based on a completely equipped

operational allweather military aircraft carrying full navigational and tactical electronics. All support equipment such as troop seats, loading ramp extensions and heavy duty floors are also included in the operational weight of the aircraft.

Where hot day performance is considered, it is based on an ISA + 41°F (22.8°C) atmosphere, and represents severe hot day conditions that may be encountered during military operations.

Experience with the Caribou I has shown the performance potential described in this section is attainable by the average pilot in typically adverse conditions as well as in ideal conditions.



## PERFORMANCE SUMMARY

ROUGH FIELD		PREPARED STRIP
34,000 lb	<i>15,422 kg</i>	Takeoff weight
34,000 lb	<i>15,422 kg</i>	Landing weight
22,550 lb	<i>10,229 kg</i>	Operational empty weight (includes crew of three at 200 lb (90.7 kg) each)
10,480 lb	<i>4,754 kg</i>	Maximum payload
0 nm		Range with maximum payload
220 kt		Cruise speed - Sea level NRP
1,000 ft	<i>305 m</i>	Takeoff distance to 50 ft (15.2 m) (firm dry sod, sea level, zero wind)
1,000 ft	<i>305 m</i>	Landing distance from 50 ft (15.2 m) (firm dry sod, sea level, zero wind)
770 fpm	<i>235 mpm</i>	Rate of climb - one engine MP
390 fpm	<i>119 mpm</i>	- ISA + 41°F (22.8°C)
2,250 fpm	<i>686 mpm</i>	Rate of climb - two engines NRP
18,000 ft	<i>5,486 m</i>	Service Ceiling - one engine MP
10,700 ft	<i>3,260 m</i>	- ISA + 41°F (22.8°C)
31,000 ft	<i>9,450 m</i>	Service Ceiling - two engines NRP
1,460 nm	<i>2,710 km</i>	Maximum range
		Cruise at 10,000 ft (3,050 m), fuel reserve per MIL-C-5011A)

(ISA conditions except where noted)

# STOL TAKEOFF DISTANCES TO CLEAR 50 FEET

Zero Wind, Firm Dry Sod  
Hot Day = ISA + 44°F (24.4°C)

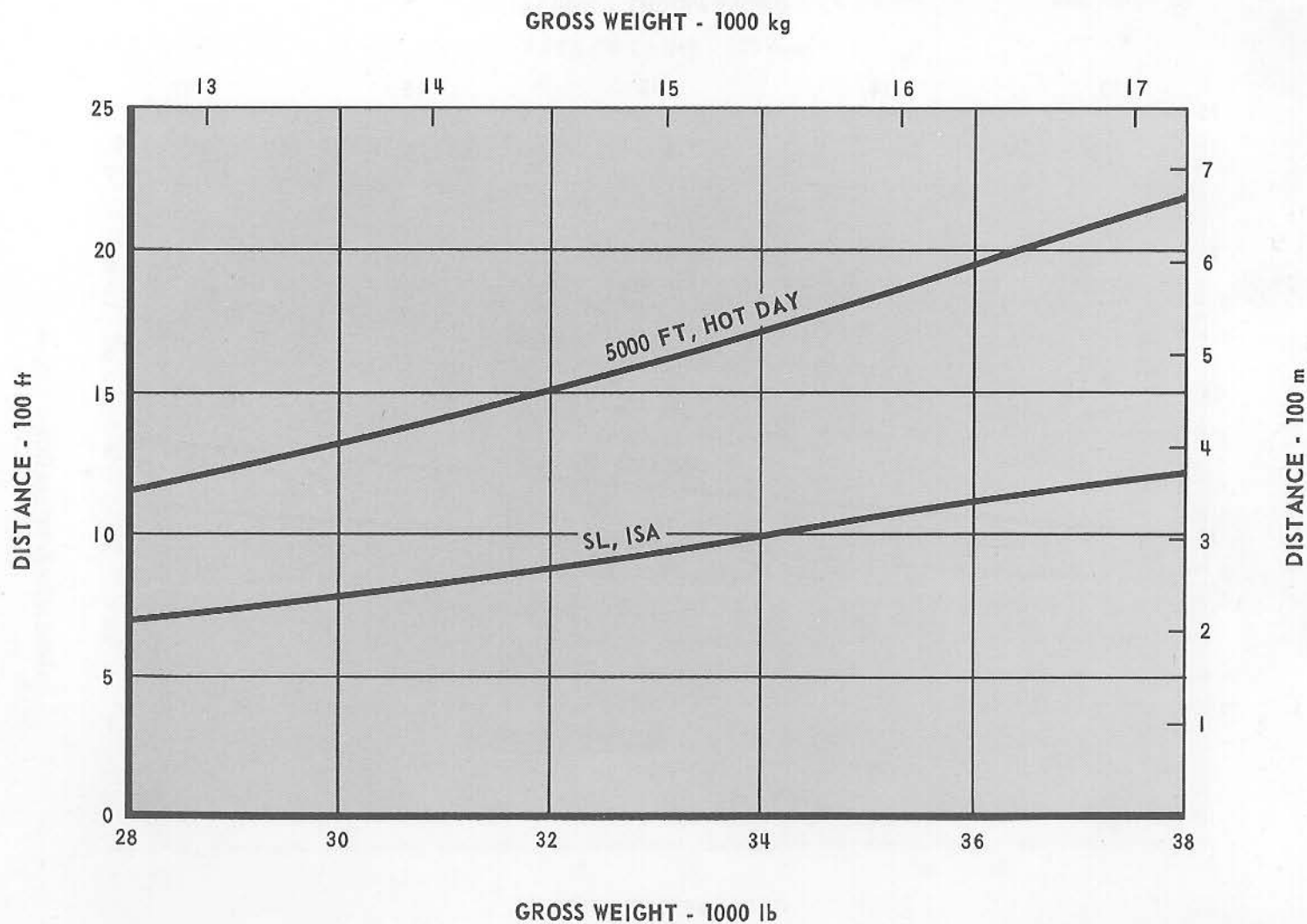

# STOL LANDING DISTANCES

FROM 50 FEET

Zero Wind, Firm Dry Sod  
Hot Day = ISA + 44°F (24.4°C)

GROSS WEIGHT - 1000 kg

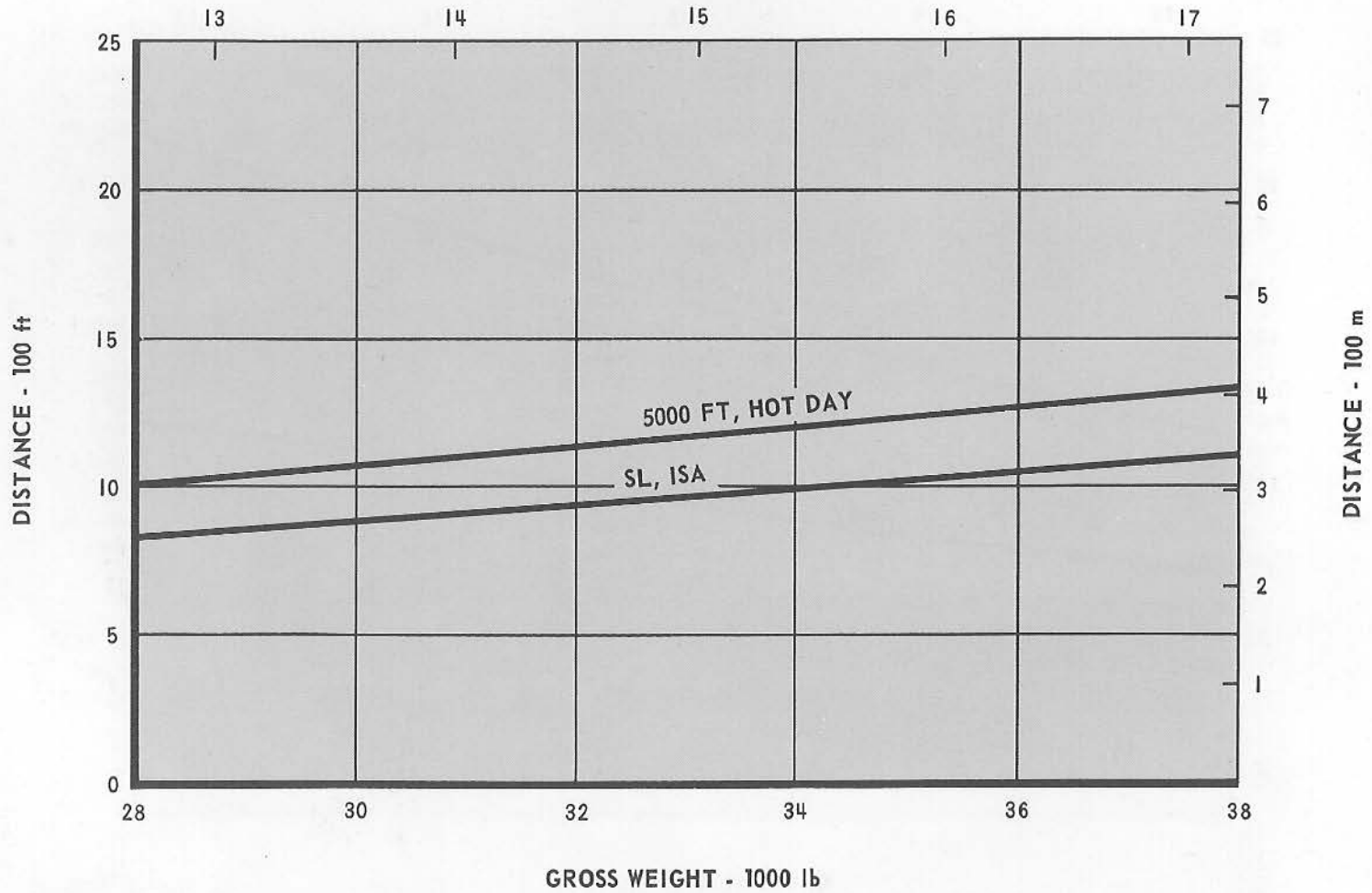

# ENROUTE CLIMB

ISA, Flaps Up

RATE OF CLIMB - 100 mpm

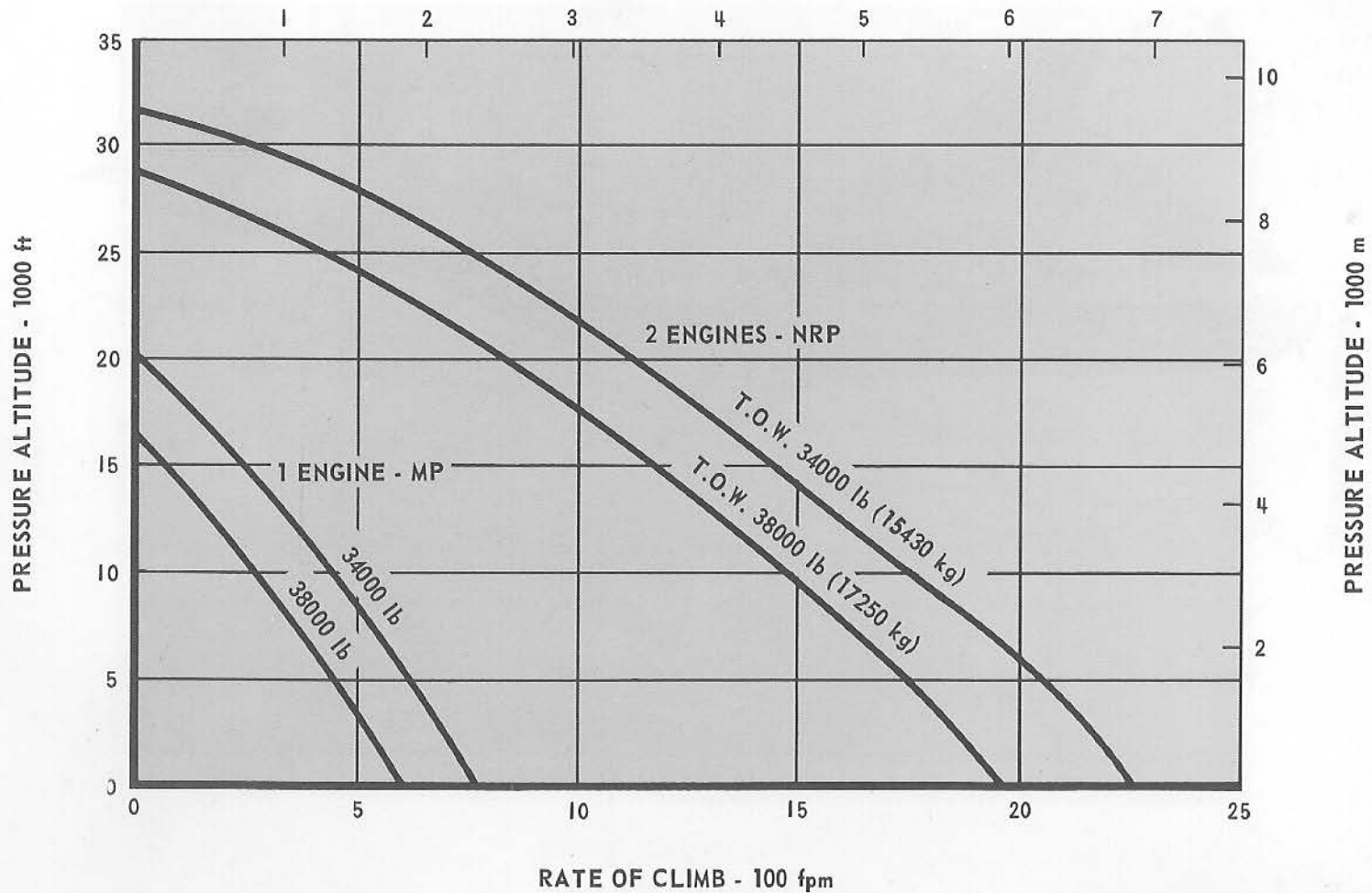

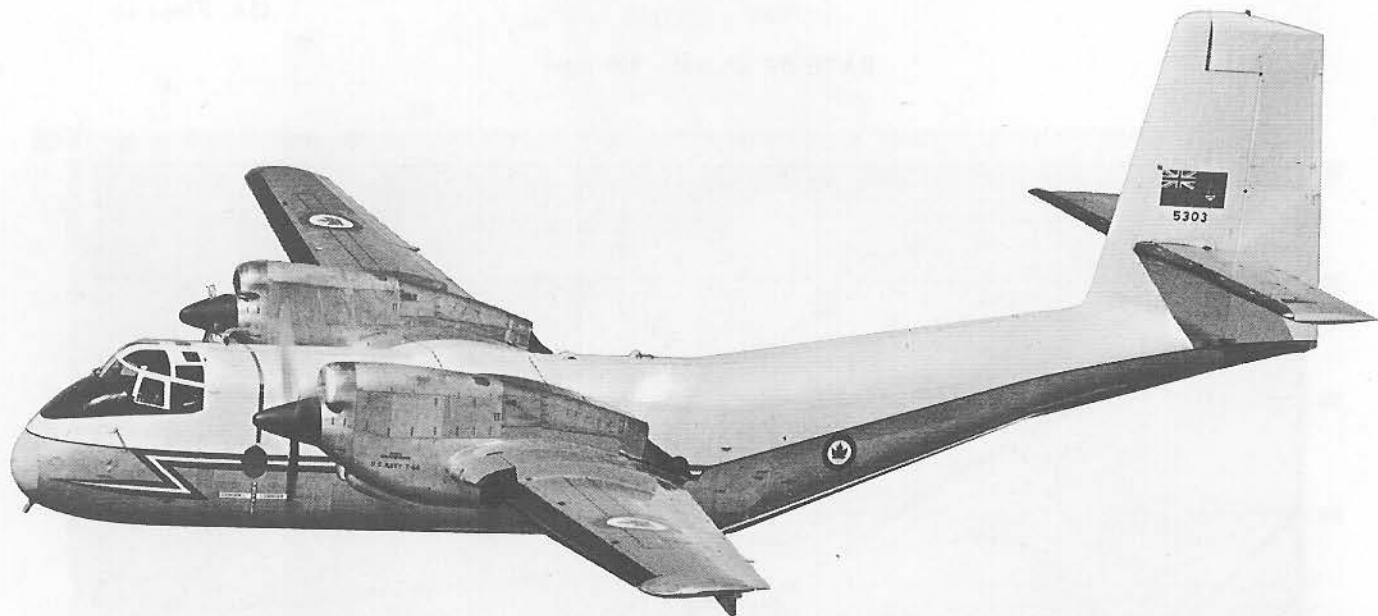

Picture opposite shows Caribou I Test Bed aircraft in flight with General Electric T-64 power units fitted. More than 250 engine hours in flight were completed by the end of March, 1963.

# PAYLOAD-RANGE

Cruise: Long Range Speed @ 5000 ft (1524 m)  
Operational Empty Weight: 22550 lb (10229 kg)  
Fuel Allowance: 5 min NRP, Warm up, Taxi & Takeoff  
Fuel Reserves: 10% of Initial Fuel

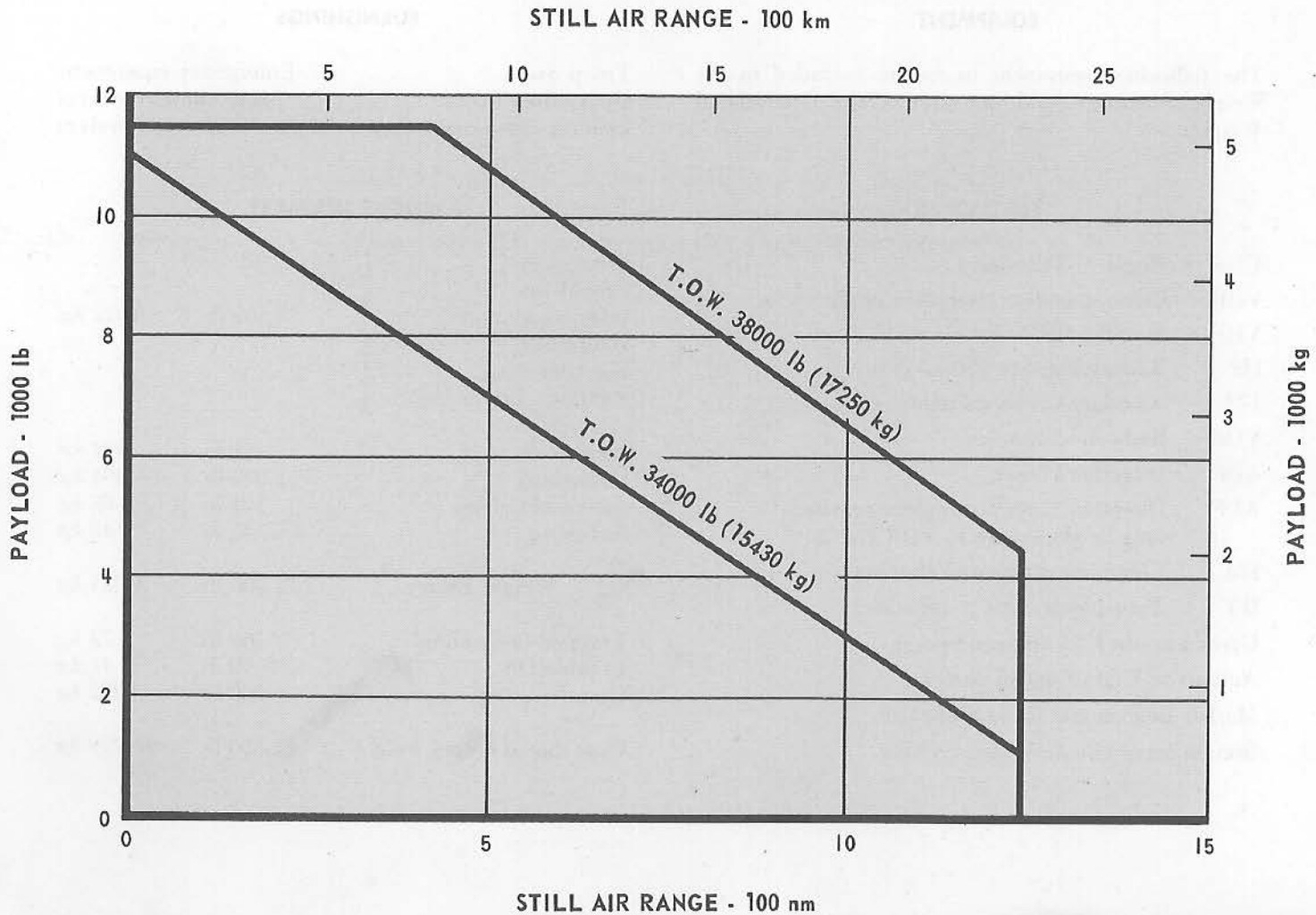

## EQUIPMENT AND WEIGHTS

### EQUIPMENT

The following equipment items are included in the Weight Summary, and are part of the Operational Weight:

### ELECTRONIC

UHF	Receiver-Transmitter
VHF	Communication (complete provision for)
VHF	Standby Radio Transmitter
HF	Radio (complete provision for)
FM	Auxiliary Communication
VOR	Radio Receiver (2)
ADF	Direction Finder
ADF	Direction Finder (complete provision only as alternative to VOR No. 2)
FM	Communications and Homing
IFF	Transponder (Air to ground)
	Gyromagnetic J.2 Compass System
	Automatic Flight Control System
	Marker Beacon and Glide Slope
	Station Intercommunication System

### FURNISHINGS

Troop Seats  
Heavy duty floors  
Loading ramp extensions

Emergency equipment  
Litter support system  
Oxygen system

### WEIGHT SUMMARY

Structure	}	19,669 lb	8,922 kg
Propulsion			
Instrumentation			
Hydraulics			
Electrics			
Auxiliary Power Unit			
Electronics		422 lb	191 kg
Furnishing		1,090 lb	494 kg
Air-Conditioning		194 lb	88 kg
Anti-icing		325 lb	148 kg
Weight Empty		21,700 lb	9,843 kg
Trapped fuel and oil		160 lb	73 kg
Useable Oil		90 lb	41 kg
Crew		600 lb	272 kg
Operational empty weight		22,550 lb	10,229 kg





**THE DE HAVILLAND AIRCRAFT OF CANADA LIMITED**  
**Downsview      Ontario**

Washington Representative: J. E. McDonald - 319 Tower Building - 14th & K Sts. N.W.  
St. Louis Representative: T. E. Hall - P.O. Box 7093 - St. Louis 77, Missouri

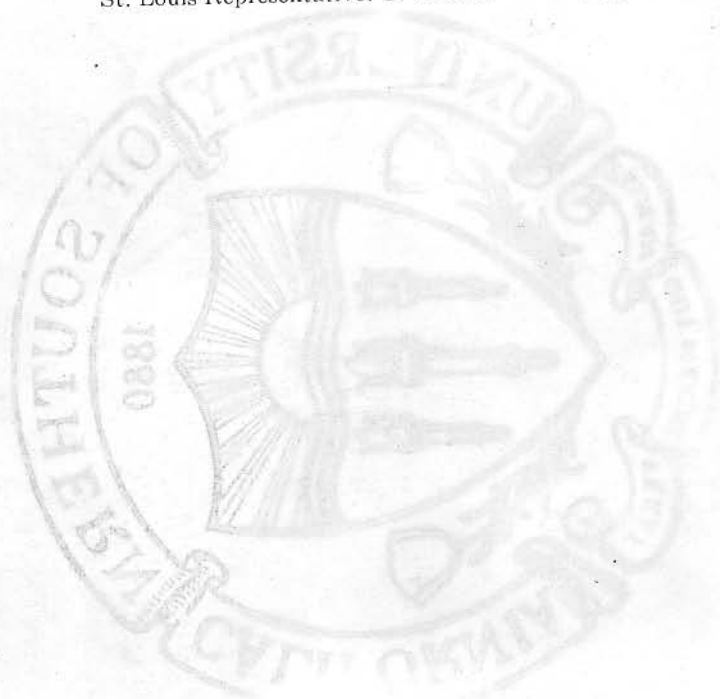

AEROSPACE SAFETY DIVISION

AVIATION SAFETY OFFICER  
LIMITED STATES ART